

PHILIPS



L.F. OSCILLOSCOPE
PM 3206

66 403 13.2-10

1/465/01

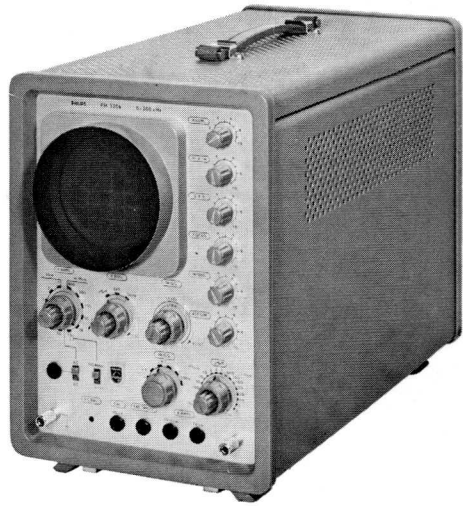

PEM 747

PHILIPS

Manual

**L.F. OSCILLOSCOPE
PM 3206**

66 403 13.2-10

1/465/01

Contents

GENERAL PART

I. Technical data	5
II. Accessories	8

DIRECTIONS FOR USE

III. Installation	9
A. Adjustment to local mains voltage	9
B. Earthing	10
C. Connection to the mains	10
IV. Operation	10
A. Knobs and sockets and their functions	10
B. Switching on	10
C. Input circuit of the vertical amplifier	10
D. Making the voltage shape visible	11
E. Determining the time	13
F. Voltage measurement	13
G. Horizontal deflection with an external voltage	13
H. Horizontal deflection with an internal sinusoidal voltage at mains frequency	14
I. Horizontal magnification	14
J. Brightness modulation	14
K. Use of the calibrating voltage	15

SERVICE DATA

V. Description of the working principle	17
A. Introduction	17
B. Attenuator	17
C. Vertical amplifier	17
D. Trigger pulse shaper	18
E. Time-base generator	18
F. Horizontal amplifier	19
G. Cathode-ray tube circuit	20

H. Calibration source	21
J. Power supply	21
VI. How to gain access to the components	28
A. Removing the cabinet	28
B. Removing the knobs	29
C. Removing the protective cap and the measuring graticule	29
VII. Replacing component parts	30
A. Replacing the thermal fuse	30
B. Replacing the safety fuses	30
C. Replacing the cathode-ray tube	31
VIII. Survey of adjusting points with relevant measuring equipment	32
IX. Adjustments	34
A. Pre-adjustments and checks	34
B. Cathode-ray tube circuit	35
C. Vertical amplifier	35
D. Calibration voltage	38
E. Horizontal amplifier	38
F. Time-base generator	39
X. Information on fault-finding	43
XI. List of component parts	44
A. List of mechanical parts	44
B. List of electrical parts	46

List of Figures

1	Rear view	9
2	Controls and their functions	11
3	View of side controls	15
4	Block diagram of the oscilloscope	25
5	Removing the panels	28
6	Removing the knobs	29
7	Removing the protective cap and the measuring lattice	30
8	Turning the cathode-ray tube	31
9	Response curves	37
10	Front view	50
11	Right-hand side view	51
12	Rear view	52
13	Left-hand side view	53
14	Printed-wiring board A	54
15	Printed-wiring board D	56
16	Printed-wiring board E	55
17	Printed-wiring board F	57
18	Printed-wiring board G	58
19	Printed-wiring board H	59
20	Printed-wiring board J	60
21	Printed-wiring board L	61
22	Printed-wiring board O	62
23	Printed-wiring board P	63
24	Y Amplifier	65
25	Time-base generator and trigger pulse shaper	71
26	X Amplifier and cathode-ray tube circuit	77
27	Supply part	83
28	Circuit diagram	85

IMPORTANT

In correspondence concerning this apparatus, please quote the type and serial numbers given on the type plate at the rear of the apparatus.

GENERAL PART

Technical data

Properties expressed in numerical values with tolerances stated are guaranteed by us. Numerical values without tolerances are given for information purposes only and indicate the properties of an average apparatus.

A. CATHODE-RAY TUBE CIRCUIT

- | | |
|--------------------------------|---|
| 1. Cathode-ray tube | D10-12GL |
| a. useful screen surface | $8 \times 6 \text{ cm } (3\frac{1}{8}'' \times 2\frac{3}{8}'')$ |
| b. deflection | symmetrical |
| c. total acceleration voltage | 2800 V |
| d. brightness control | d.c.-coupled |
| 2. Brightness modulation | |
| a. voltage required | 30 V for frequencies up to 1 kc/s |
| b. input impedance | 600 k Ω //25 pF |
| 3. Mechanical beam suppression | The beam is suppressed when a plug is inserted in an input socket. If this socket is subsequently earthed, the trace reappears. |
| 4. Measuring graticule | $8 \times 6 \text{ cm}$, smallest subdivision 2 mm. The graticule illumination can be regulated. |

B. Y AMPLIFIER (VERTICAL DEFLECTION)

- | | |
|-----------------------|--|
| 1. Deflection factor | 13 calibrated steps: 0.002 - 0.01 - 0.02 - 0.05 - 0.1 - 0.2 - 0.5 - 1 - 2 - 5 - 10 - 20 - 50 V/cm. Tolerance $\pm 3\%$. Continuous adjustment is possible between the steps (not calibrated). |
| 2. Frequency response | 0-100 kc/s (max. drop 3 dB) for sensitivity from + 2 mV/cm.
0-300 kc/s (max. drop 3 dB) for sensitivities from 10 mV-50 V/cm. |

The band width is almost constant in all positions of the step attenuator, but varies slightly when the continuous attenuator is moved.

- | | |
|---|--|
| 3. Overshoot | $\leq 0.5\%$ for pulses with rise times ≥ 30 ns. |
| 4. Input | asymmetrical, d.c. or a.c. coupled (switchable) |
| a. input resistance | 0.5 M Ω |
| b. input capacity | positions 0.01-0.02 and 0.05 V/cm: ≤ 50 pF
other positions: ≤ 20 pF |
| c. max. permissible
d.c. voltage with
a.c. coupling | 300 V |

C. CALIBRATING VOLTAGE (SOCKET "CAL.")

square-wave voltage of 40 mV_{p-p} ($\pm 1\%$),
frequency equal to the mains frequency

D. X AMPLIFIER (HORIZONTAL DEFLECTION)

- | | |
|--|--|
| 1. Deflection factor | 1 V/cm
attenuation with continuous control and/or
fixed attenuator 1 : 10 (2 input sockets) |
| 2. Frequency-response curve | 0-300 kc/s (-3 dB) |
| 3. Input | asymmetrical |
| a. input impedance | 1 : 1-input: 100 k Ω //30 pF,
1 : 10-input: 1.1 M Ω //6 pF |
| b. max. input voltage | 1 : 1-input: 100 V _{p-p} ,
1 : 10-input: 700 V _{p-p} |
| 4. Horizontal-deflection
voltages, by selection | a. the internal time-base voltage
b. an external voltage
c. an internal voltage with mains frequency |
| 5. Magnification | |
| a. with horizontal
deflection by means of
the internal time-base | $\times 1$ or $\times 5$, tolerance $\pm 3\%$, with respect to the
" $\times 1$ " position |
| b. with horizontal
deflection by means of
an external voltage | continuous up to 5×8 cm |

E. TIME BASE GENERATOR

1. Sweep times
18 calibrated times: 2 - 5 - 10 - 20 - 50 - 100 - 200 - 500 $\mu\text{s}/\text{cm}$, 1 - 2 - 5 - 10 - 20 - 50 - 100 - 200 - 500 ms/cm , 1 s/cm , tolerance $\pm 3\%$.
When expanded via the horizontal amplifier ($5 \times$) the shortest sweep time is 0.4 $\mu\text{s}/\text{cm}$. The sweep times can be varied continuously between steps (not calibrated).
2. Modes of operation
 - a. free-running
 - b. triggered
3. Triggering
by selection, internally + or - (L.F. or H.F.), externally + or - (d.c. or H.F.) or internally with the mains frequency + or -
 - a. sensitivity, internal
0.5 cm trace height for frequencies ≥ 1 c/s
 - b. sensitivity, external
1 V_{p-p} for frequencies from 0-300 kc/s input impedance: 1 $M\Omega//40$ pF
Max. external triggering voltage is 3 V_{p-p} .
4. Trigger level
Trigger level can be continuously adjusted internally across 6 cm ($2\frac{3}{8}$ ") picture height; externally across 12 V.
5. Output voltage at socket "45 V "
sawtooth voltage of 42 V_{p-p} , d.c. level + 20 V.
the load may be max. 0.1 $M\Omega//35$ pF,

F. SUPPLY

Can be changed over for mains voltages of 110-127 and 220 V. The mains frequency may be 40-100 c/s. With mains frequencies < 50 c/s, the mains voltage must not exceed the nominal value.

The power consumption is 135 W.

G. INFLUENCE OF MAINS-VOLTAGE VARIATIONS OF $\pm 10\%$

The vertical and the horizontal-deflection sensitivities (sweep times) slightly vary at mains voltage variations. The calibrating voltage, however, remains constant.

H. MECHANICAL DATA

Dimensions	height 30 cm ($11\frac{3}{16}$ " width 21.5 cm ($8\frac{7}{16}$ " depth 45 cm ($1' 5\frac{3}{4}$ "
Weight	14 kg (30.86 lbs.)

Accessories

- 1 mains cable
- 1 manual (Directions for Use + Service Notes)
- 1 measuring cable, length approx. 1 m, with 4-mm plugs at each end.

DIRECTIONS FOR USE

Installation



A. ADJUSTMENT TO LOCAL MAINS VOLTAGE

The apparatus can be adjusted, by means of a voltage adapter, to mains voltages of 110, 127 or 220 V.

The required value can be read through the opening in the rear panel (Fig. 1).

Adjustment to other mains voltages is effected as follows:

- a. Remove the screws "A" and detach the rear panel.
- b. Pull out the adapter slightly, turn it until the correct voltage is uppermost and push back.
- c. Fit the rear panel again.

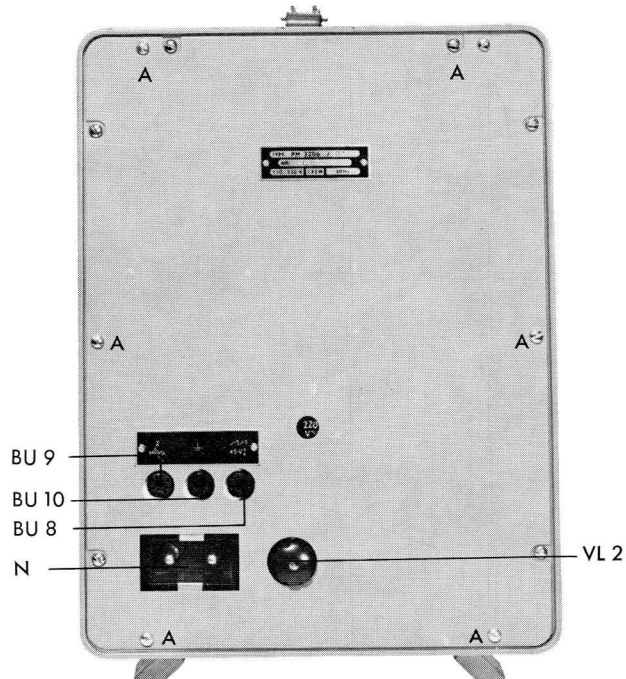

Fig. 1. Rear view

B. EARTHING

The apparatus should be earthed in conformity with local safety regulations. This can be done:

- a. via one of the earthing sockets at the front (see Fig. 2), or
- b. via the mains cable when the apparatus is equipped with a three-core mains cable fitted with a plug with an earthing contact.

Double leads may give rise to hum and must therefore be avoided.

C. CONNECTIONS TO THE MAINS

- a. Make sure that the mains-voltage adapter is correctly adjusted.
- b. Earth the apparatus.
- c. Set the mains switch "ILLUM." at "0".
- d. Connect the mains input socket ("N", Fig. 1) to the mains with the cable provided.

Operation

IV

A. KNOBS AND SOCKETS AND THEIR FUNCTIONS

Please refer to Fig. 2.

B. SWITCHING ON

Switch on the apparatus by turning the control "ILLUM." clockwise. This control also serves for graticule illumination.

C. INPUT CIRCUIT OF THE VERTICAL AMPLIFIER

The signal to be tested is connected to the socket marked "Y AMPL.". When the switch "AC/DC" is in the position "DC" the amplifier is d.c. coupled to the input. In the position "AC" a blocking capacitor is interposed between the input and the amplifier.

D. MAKING THE VOLTAGE SHAPE VISIBLE

1. Preliminary adjustment

- Set all knobs to the positions indicated in Fig. 2.
- Turn the knob "TRIGG.-STAB." clockwise until the time-base line appears.
- Adjust the line to the middle of the screen by means of the knobs " $\leftarrow X \rightarrow$ " and " $\downarrow Y \uparrow$ ".

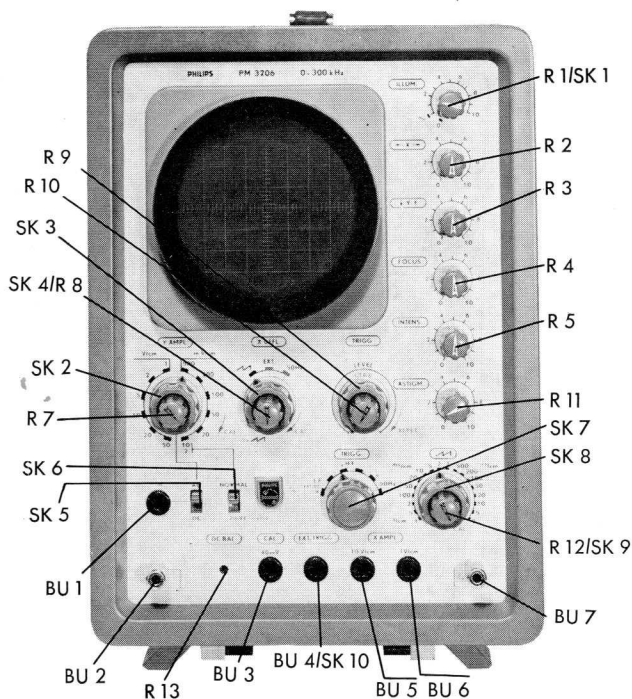





Fig. 2. Controls and their functions

- R 9 Trigger level
- R 10 Trigger stability
- SK 3 Selection of horizontal deflection voltage
- SK 4/R 8 Magnification $\times 1$ or $\times 5$ in position  of SK 3
- Continuous control in other positions of SK 3
- SK 2 Step control vertical sensitivity
- R 7 Continuous control vertical sensitivity
- SK 6 Sensitivity increase switch
- SK 5 AC/DC selection for the input
- BU 1 Input to the vertical amplifier
- BU 2 Earth socket
- R 13 Fine balance control for vertical amplifier
- BU 3 Calibration voltage
- BU 4/SK 10 Input for external trigger
- BU 5/BU 6 Inputs to the horizontal amplifier
- BU 7 Earth socket
- R 12/SK 9 Continuous control of sweep times
- SK 8 Setting of calibrated sweep times
- SK 7 Selection of trigger voltage
- R 11 Astigmatism
- R 5 Brightness
- R 4 Focusing
- R 3 Vertical shift
- R 2 Horizontal shift
- R 1/SK Mains switch
Lattice illum.

- d. Adjust the brightness and the definition of the picture with the knobs "INTENS.," "FOCUS" and "ASTIGM."

Stationary pictures of intense brightness may cause permanent damage if they are on the screen for a long time.

2. Time-base internally triggered

- a. Set the switch "TRIGG." to the position "+HF" or "-HF". Use the positions "+LF" and "-LF" at low frequencies only (< approx. 30 c/s). At very low frequencies (0-1 c/s) external triggering must be applied (see the following section).
- b. Make the time-base line visible as described under "Preliminary adjustment".
- c. Set the "AC/DC" switch to the desired position.
- d. Connect the voltage to be tested to the socket "Y AMPL." and adjust the picture height to the required value by means of the switch "Y AMPL." (or with the continuous control if required). The vertical sensitivity, however, is only calibrated when the continuous control is in the position "CAL." (turned fully clockwise).
- e. Adjust to the approximate sweep time required with the switch "
- f. Turn the knob marked "TRIGG.-STAB." anti-clockwise until the trace just disappears (the knob "TRIGG.-LEVEL" is still turned anti-clockwise).
- g. Now turn the knob "TRIGG.-LEVEL" clockwise until the time-base starts and the trace becomes visible again. This can now be further adjusted until the time-base starts at the desired level of the voltage under test.
- h. Further adjust the sweep time with the switch "
- i. Adjust the knob "TRIGG.-LEVEL" and/or "TRIGG.-STAB." a little further if necessary. If desired, the picture can now be magnified in the horizontal direction by means of the control "X DEFL."

3. Time-base externally triggered

Connect the external trigger voltage to the socket "EXT. TRIGG.". As soon as a plug is inserted in this socket, the internal trigger voltage is switched off and the external trigger voltage is connected to the input of the trigger pulse shaper. For triggering with frequencies of over approx. 30 c/s, set the switch "TRIGG." to the position "+HF" or "-HF". When the switch "TRIGG." is in the position "+LF" or "-LF", the

input circuit for the external trigger voltage is d.c. coupled and can be triggered with very low frequencies or with a direct voltage. For the rest proceed as for internal triggering.

4. Time-base internally triggered with the mains frequency

Set the switch marked "TRIGG." at the position "+50 Hz" or "-50 Hz". Then proceed as described in section 2 "Time-base internally triggered".

E. DETERMINING THE TIME

The sweep time per cm can be determined from the position of the knob "".

When the picture is magnified $5\times$ in horizontal direction (see section I "Horizontal magnification") the sweep time per cm is $5\times$ smaller than is indicated by these knobs.

F. VOLTAGE MEASUREMENT

When the continuous control "Y AMPL." is in the position "CAL." (turned fully clockwise), the value of the voltage connected to the socket "Y AMPL." can be determined immediately from the picture height and the position of the step attenuator "Y AMPL."

Switch "NORMAL-2 mV" enables the sensitivity of the amplifier to be increased when the attenuator is set to maximum sensitivity. Thus with switch "Y AMPL." at "10 mV/cm" and switch "NORMAL-2 mV" at "2 mV" the sensitivity is 2 mV/cm.

For calibration at the vertical sensitivity see chapter IV. K "Use of the calibration voltage".

G. HORIZONTAL DEFLECTION WITH AN EXTERNAL VOLTAGE

The time-base generator is switched off when the switch "X DEFL." is at the position "EXT.". Both the vertical and the horizontal deflection can then take place with an external voltage, so that, for example, frequency measurements can be carried out with the aid of Lissajous figures.

The external voltage for horizontal deflection is connected to one of the sockets "X AMPL." ("10 V/cm" or "1 V/cm"). The horizontal amplitude can be varied with the continuous control "X DEFL.".

H. HORIZONTAL DEFLECTION WITH AN INTERNAL SINUSOIDAL VOLTAGE AT MAINS FREQUENCY

For this purpose set the switch "X DEFL." at the position "50 Hz". The horizontal amplitude can be varied with the continuous control "X DEFL.", as in position "EXT." the time-base generator is disconnected.

I. HORIZONTAL MAGNIFICATION

When the internal time-base voltage is used, the picture can be magnified in the horizontal direction with the switch part of the control "X DEFL.". When this knob is at the position "5×  (turned fully anti-clockwise), the magnification is 5×. When this knob is turned clockwise, so that the switch changes over (position "CAL."), the magnification is 1×. When the knob "X DEFL." is at the position "EXT." or "50 Hz", the horizontal amplitude can be regulated with the potentiometer part of the control "X DEFL.".

J. BRIGHTNESS MODULATION

The voltage required for brightness modulation should be connected to the socket "Z-MOD." at the rear of the apparatus (see Fig. 1). This voltage should be approx. 30 V.

If a plug is inserted in the socket "Z-MOD.", the electron beam is suppressed (and consequently the picture disappears). If subsequently this plug is connected to the chassis (socket ""), the trace reappears.

K. USE OF THE CALIBRATING VOLTAGE

With the aid of the calibrating voltage the vertical sensitivity can be calibrated as follows:

1. Set "X DEFL." to the position "CAL." (turned fully clockwise).
2. Set the "Y AMPL." switch to position " $\frac{10}{2}$ ".
3. Set the switch "AC/DC" to the position "DC".
4. Connect the socket "CAL." to the input of the vertical amplifier.
5. Make the trace visible as described in section D2 "Time-base internally triggered".
6. The picture height must now be exactly 4 cm. If not, the potentiometer "GAIN ADJ." (see Fig. 3) must be adjusted until the picture height is 4 cm.

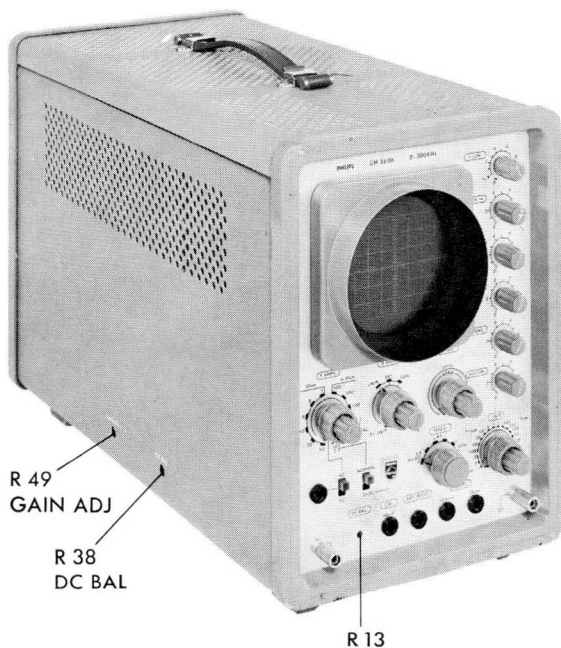
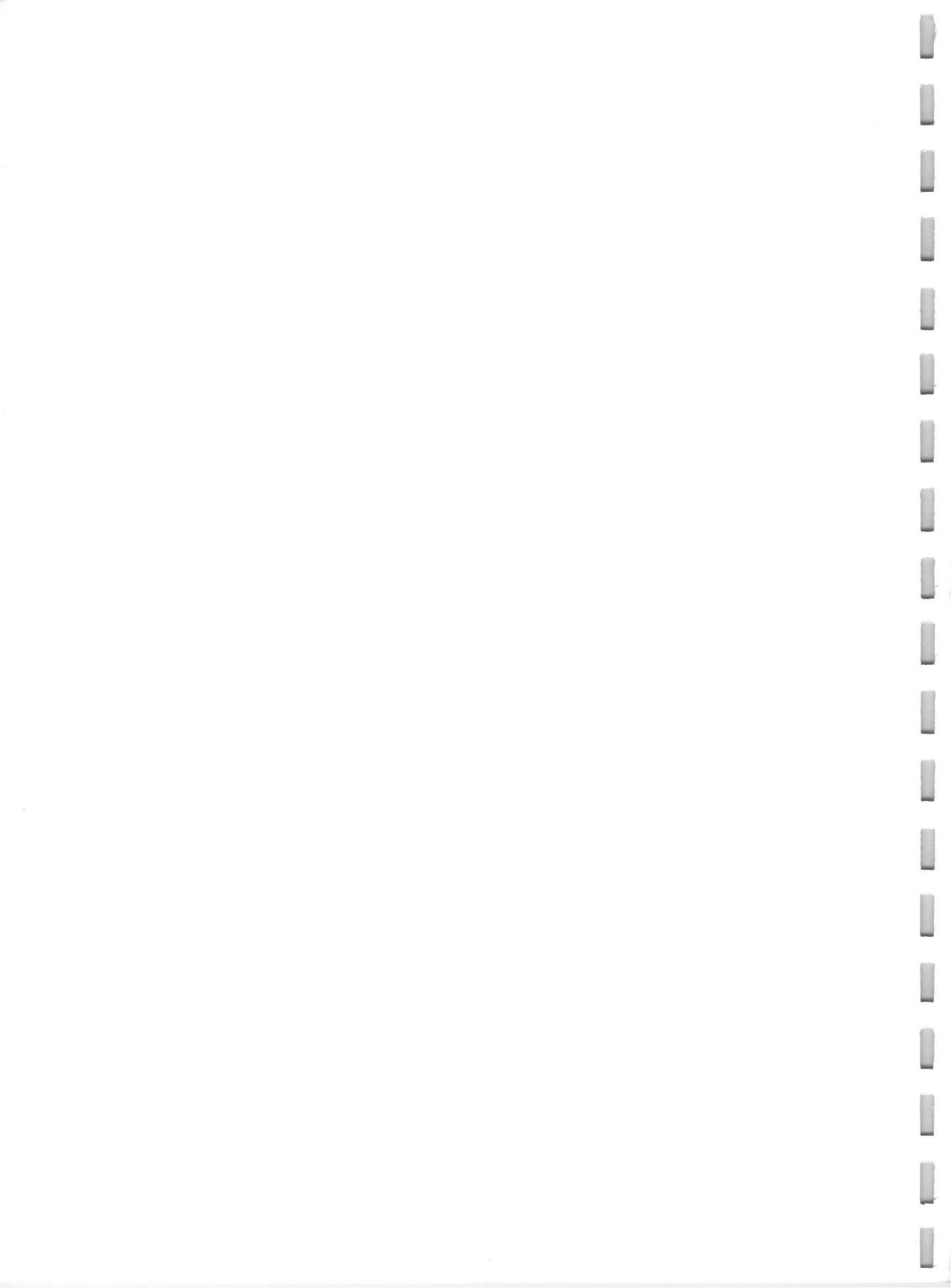

Fig. 3. View of side controls



SERVICE DATA

Description of the working principle



A. INTRODUCTION

The input signal is connected via the stepped attenuator to the vertical amplifier, the output stage of which drives the vertical deflection plates of the cathode-ray tube. A trigger output is fed from the vertical amplifier to the pulse-shaper for internal triggering. An input is also provided for external triggering.

The trigger circuit produces output pulses which gate the horizontal sweep-circuit at the correct time. The sawtooth output waveform of the sweep-circuit is amplified by the horizontal amplifier and applied to the horizontal deflection plates of the cathode-ray tube. When an external sweep signal is used this is connected to the horizontal amplifier directly via the "X AMPL." sockets.

The calibration voltage source provides a square-wave output which can be used for calibration of the vertical deflection system via the amplifier.

B. ATTENUATOR

The input signal is applied to socket "Y AMPL." and thence to the amplifier via an attenuator network selected at switch "Y AMPL." (SK2). Switch "AC/DC" (SK5) switches the blocking capacitor C7 in or out as required. The attenuator consists of five sections which provide 12 different attenuation positions. Trimmers C1-C3-C5-C11-C71-C72 and C74 provide frequency-independent adjustment of the attenuators.

C. VERTICAL AMPLIFIER

The amplifier consists of a phase inverter stage (B1-B2) and a balanced output stage (B3-B4). Switch "NORMAL - 2 mV" changes the cathode resistance of stage (B1-B2). When switch "Y AMPL." is at "10 mV/cm" and switch "NORMAL - 2 mV" at "NORMAL" the sensitivity is 10 mV_{p-p}/cm.

Switching to "2 mV" increases the sensitivity to $2 \text{ mV}_{p-p}/\text{cm}$ (in both cases with continuous control "Y AMPL." (R7) at "CAL.>"). Potentiometers R38 (coarse) and R13 (fine) serve for the balancing of the output stages.

Potentiometer " $\downarrow Y \uparrow$ " (R3) provides the vertical shift facility and choice resistor R44 provides for range of adjustment of R3.

Potentiometer R49 serves for the adjustment of the sensitivity of the amplifier.

D. TRIGGER PULSE SHAPER

This circuit consists of a cathode-coupled stage (B9-B9') and a Schmitt trigger circuit (B10-B10').

Trigger signals derived from the vertical amplifier, mains internal or an external source, by selection, are formed into narrow trigger pulses of constant amplitude.

Switch "TRIGG." (SK7) serves for polarity selection of the trigger signals. Internal triggering is automatically cut off by insertion of a plug into socket "EXT. TRIGG." (BU4, SK10).

Control "TRIGG. LEVEL" (R9) determines the magnitude of the d.c. voltage level on the grid of B9, hence the level of the input voltage at which the time base is triggered.

The threshold voltages of the Schmitt trigger circuit are adjustable by R137.

Because the Y amplifier is d.c. coupled, if the RC time of the input circuit is large the trace may disappear for some time when control " $\downarrow Y \uparrow$ " is turned. Therefore, with internal triggering, with switch "TRIGG" (SK7) in positions "+HF" and "-HF", a small capacitance C28 is connected in series with C26. In the case of external triggering, with positions "+LF" and "-LF", the coupling is direct and in positions "+HF" and "-HF" C28 remains connected.

E. TIME-BASE GENERATOR

The time-base generator consists of a Schmitt trigger (B12-B12') (time-base trigger circuit), two blocking diodes (GR1 and B13' circuited as a diode), a Miller-integrator (B14) (sweep circuit) and three cathode followers (B11'-B13-B14'). It can function either free-running or triggered.

1. Time-base trigger circuit

The trigger pulses from the pulse shaper are applied to the Schmitt trigger (B12-B12'), which switches at a certain level determined by the setting of R159. When this occurs an output pulse starts the sweep circuit. The valves of the Schmitt trigger are coupled via cathode follower B11' in order to keep the rise time of the pulses small.

The circuit acts as an electronic switch for the sweep circuit. When the trigger pulse is applied the Schmitt circuit switches, diodes GR1 and B13' are cut off and the Miller "run-down" commences.

2. Time-base sweep circuit

The Miller integrator (B14) provides an extremely linear sawtooth output waveform, built up on a timing capacitor. The rate at which the charge builds up, on this capacitor, determines the sweep time/cm.

The rate of charge is, in turn, dependent on the time-constant of the timing capacitor and resistor selected by means of switch "∩∩" (SK8). Feedback is applied to the timing capacitor via cathode follower B14' to reduce nonlinearity in the charging of the capacitor, thus ensuring a linear sawtooth output waveform. The output to the horizontal amplifier is taken from the junction of R171 and R172 and an external output is available at BU8.

The sawtooth waveform from the sweep cathode follower is applied via cathode follower B13 to the input of B12 for resetting the trigger circuit at the end of each sweep.

The d.c. level at the input of B12 is controlled by potentiometer "TRIGG. STAB." (R10). This can be set to permit triggering or free running of the time-base circuit. R170 controls the length of the time-base line on the screen.

Sweep time selection with switch "∩∩" (SK8) provides 18 calibrated times which are adjustable with C43 and R178-R182. Continuous sweep time variation is available at control "∩∩" (R12).

F. HORIZONTAL AMPLIFIER

The amplifier consists of a cathode-coupled, push-pull stage which amplifies the saw-tooth signal and controls the horizontal deflection plates symmetrically. The amplification is adjustable with R98 and horizontal shift is effected with control "←X→" (R2).

The horizontal deflection source is chosen with switch "X DEFL." (SK3) which has three positions, as follows:

1. “” Horizontal deflection with internal sawtooth waveform

The signal is fed via a fixed attenuator or directly coupled (SK4), i.e., $\times 1$ and $\times 5$ magnification, respectively.

The $\times 1$ magnification gives rise to a time-base line of 8 cm.

The attenuator can be adjusted for frequency independence with C25. R83 and C18 ensure that the load on the time-base generator remains the same for both positions of SK4.

2. “EXT.” Horizontal deflection with an external voltage

The time-base generator is switched off (by removal of the earth from R10 at SK3).

The external voltage can be connected to either BU6 or BU5.

The input at BU5 is attenuated up to $10\times$ (compared with BU6) by R87 and R8. The amplitude of the input can be continuously varied with R8.

3. “50 Hz” Horizontal deflection with internal voltage at mains frequency

This voltage is taken from winding S7 of the supply transformer.

The amplitude is continuously variable with R8.

G. CATHODE-RAY TUBE CIRCUIT

1. Brightness control

The anode voltage of B12 is taken to the first grid of the c.r.t. via B11' so that the electron beam is unsuppressed during the forward sweep of the time-base.

C34 and C35 ensure that the pulses reach the c.r.t. grid without distortion, so that at all sweep times the time-base line has even brightness over its whole length. When SK3 is at “EXT.”, R10 is not earthed, B13 is cut off, B12' remains cut off and the c.r.t. is constantly bright.

2. Brightness modulation

When a plug is inserted into BU9, SK11 switches, R117 is short-circuited and the electron beam is suppressed.

If BU9 is earthed the trace reappears. When an a.c. voltage is applied to BU9 the beam is interrupted periodically.

3. Astigmatism

The voltage on the second grid of B15 can be varied with potentiometer "ASTIGM." (R11) thus ensuring sharp focusing, both horizontally and vertically, with the same voltage on the focusing anode.

4. Focussing

The voltage on the focusing anode can be regulated with control "FOCUS" (R4).

H. CALIBRATION VOLTAGE SOURCE

A square-wave voltage of 40 mV_{p-p} is available at socket "CAL." (BU3), by using two diodes (B21 and B21') for clipping an a.c. voltage of between -65 V and -150 V , derived from the supply transformer.

Further attenuation is carried out by the potential divider R233, R226, R227 and R228. Final amplitude of 40 mV is set by selection of R226 and R233.

J. POWER SUPPLY

1. +385 V

Non-adjustable, obtained from rectifier circuit GR6-9.

2. +2100 V

Obtained via an additional winding on the supply transformer and rectifiers GR11-16, and added to +385 V.

3. -150 V

Obtained with rectifier circuit GR17-20. Regulated by B18 and B17. The reference voltage being derived with the stabilising valve B19. The output is adjustable with R213.

4. +240 V

Regulated voltage obtained by regulating +385 V with B16 and B17'. The reference voltage is derived from the -150 V line.

5. -65 V

Derived from the stabilising valve B19,

6. -420 V/-770 V

Obtained from the voltage doubler GR4, GR5 supplying two voltages which together with the stable -150 V give -420 V and -770 V.

The -770 V is regulated with B20, the regulated +240 V being used as a reference. The -770 V is adjustable at R232.

7. -6.3 V

Heater supply for valves B1 and B2. The a.c. voltage is derived from windings S7 and S8 of transformer T1 and rectified at GR2.

Electronically stabilised with transistors TS1, TS2 and TS3 and Zener diode GR10.

Output is adjustable at R65.

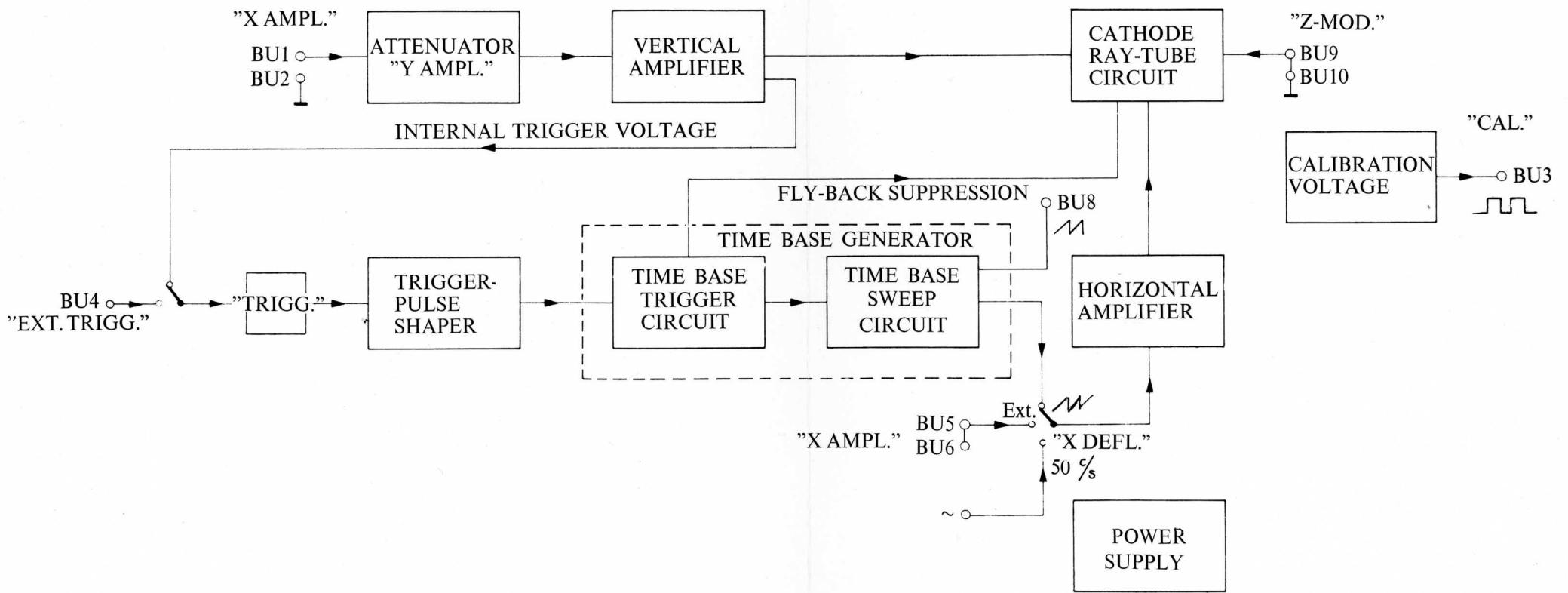

PEM 845 E468

Fig. 4. Block diagram of the oscilloscope

How to gain access to the components

VI

A. REMOVING THE CABINET (see Fig. 5)

Caution! Very high voltages are generated in this apparatus, so that when work is carried out on the inside of the apparatus great care must be taken.

The cabinet consists of a number of separate plates which may be individually detached.

Rear plate

1. Loosen and remove the six screws "A".
2. Remove the rear plate.

Top plate and side plates

1. Loosen and remove the screws "B".
2. Push the plate forward and lift it out of the frame.

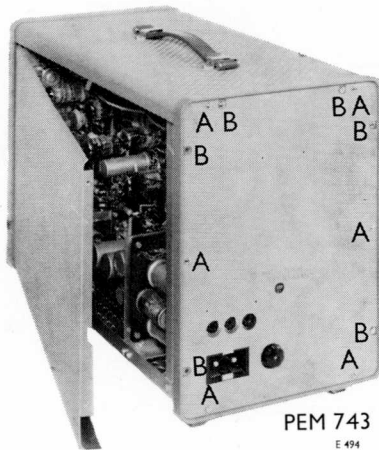

Fig. 5. Removing the panels

Bottom plate

1. Loosen and remove the screws with which the two strips with rubber studs are fastened.
2. Remove the bottom plate.

B. REMOVING THE KNOBS (see Fig. 6)

Single knobs

1. Remove the cap "A".
2. Loosen the small screw "B".
3. The knob can now be removed from the spindle*.

Double knobs

1. Remove the cap "A".
2. Loosen the small screw "B".
3. The inner knob can now be removed from the spindle*.
4. Loosen the nut "C".
5. The outer knob can now also be removed from the spindle*.

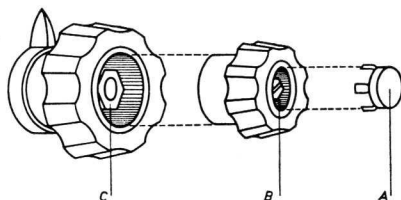

E 467

Fig. 6. Removing the knobs

C. REMOVING THE PROTECTIVE CAP AND THE MEASURING GRATICULE

1. Grip the protective cap as shown in Fig. 7 and pull back the lower part.
2. The protective cap, the measuring graticule and the plate of contrast improving material can now be successively removed.

* If the knob sticks, press a screwdriver against the screw and pull the knob at the same time so that the clamping cone releases.

Replacing component parts

VII

All valves and other component parts have been taken from normal production. After replacing valves or component parts it may be necessary to readjust the relevant circuit. See chapter IX "Adjustments". During the replacement of valves or component parts the apparatus must be switched off.

A. REPLACING THE THERMAL FUSE (see Fig. 12)

This fuse blows when the temperature of the supply transformer becomes too high. A new fuse (code number 974/T125) must be attached to the small spring "S" and pulled over the small hook "H".

B. REPLACING THE SAFETY FUSES

The fuse holder is located at the rear of the apparatus (VL2). It contains a 1.6-A fuse.

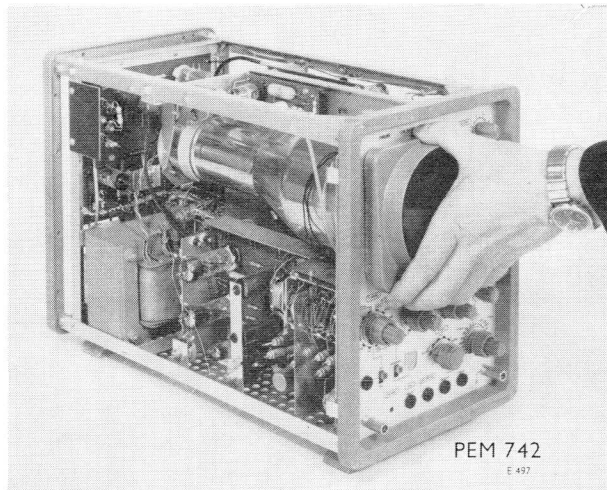

Fig. 7. Removing the protective cap and the measuring lattice

C. REPLACING THE CATHODE-RAY TUBE

1. Loosen the plug for the post-acceleration voltage, located at the bottom of the tube.
2. Remove the protective cap (see chapter VI. C).
3. Insert a screwdriver with a narrow blade into one of the recesses of the tube holder, specially intended for this purpose. Using the screwdriver as a lever, the tube can be slid forward. At the same time press the forefinger of the left hand against the central pin of the tube holder, if necessary.
4. When the new cathode-ray tube has been fitted, make sure, that the time-base line runs completely horizontally. If not, turn the tube to the correct position with lever "H" (see Fig. 8) (first loosen the screws "K").

After the cathode-ray tube has been replaced, the vertical sensitivity and the sweep times must be checked and, if necessary, adjusted (see chapter IX. C and F).

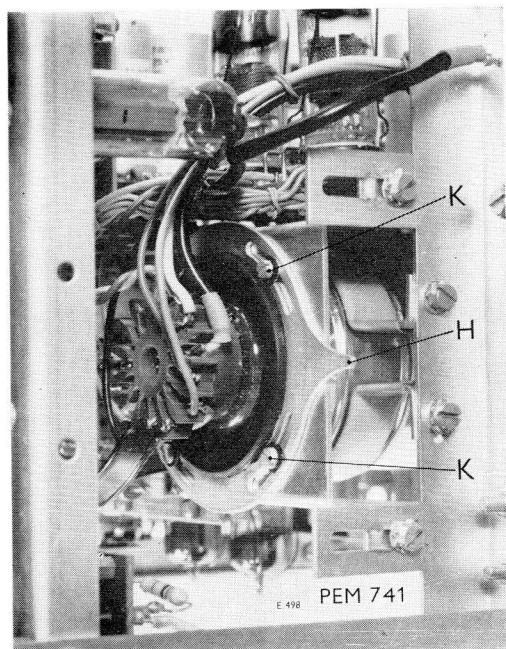

Fig. 8. Turning the cathode-ray tube

Survey of adjusting points with relevant measuring equipment



<i>Adjustments</i>	<i>Adjusting element</i>	<i>Unit</i>	<i>Measuring equipment</i>	<i>Recommended</i>	
				<i>PHILIPS equipment</i>	<i>Chapter IX, point</i>
Vertical amplifier					
Sensitivity	R49, R34	L	square-wave generator	GM 2314	C.3
DC balance	R38, R13, R44	L	none		C.1
Square-wave response	C1, C3, C5, C11, C71, C72, C74	H	square-wave generator	GM 2314 GM 2324	C.7
Horizontal amplifier					
Sensitivity	R98	E	none		E.1
Square-wave response	C24	E	square-wave generator oscilloscope	GM 2314 GM 2324 GM 5602 PM 3230	E.2
Time-base generator and trigger pulse shaper					
Trigger stability	R159*, R170*	F	L.F. oscilloscope RC generator d.c. voltmeter	GM 5602, PM 3230 PM 5120 GM 6020	F.1
Trigger sensitivity	R177	E	none		F.1
Calibrating the sweep times	R178, R179, R180, R181, R182, C43, C25	O, C	sine generator	PM 5120	F.6

* These potentiometers must be adjusted at the same time.

<i>Adjustments</i>	<i>Adjusting element</i>	<i>Unit</i>	<i>Measuring equipment</i>	<i>Recommended PHILIPS equipment</i>	<i>Chapter IX, point</i>
Cathode-ray tube circuit					
Brightness control	R115	G	d.c. voltmeter	GM 6020	A
Flyback suppression	C35, R111	F, G	none		B.1
Distortion	R69	G	none		B.2
Supply voltages					
-150 V	R213	P	d.c. voltmeter	GM 6001 GM 6020	A
-770 V	R232	P	d.c. voltmeter		A
Calibrating voltage	R226, R233	A	RC generator	PM 5120	D

NOTE:

For checking and adjusting the apparatus the sequence in chapter IX should be followed and not that of the above table.

Adjustments

IX

The tolerances given here are factory tolerances, which can only be used when the apparatus is readjusted. They may differ from the "Technical data" (General Part, Chapter I). The survey of all controls with their functions is given in chapter IV.

A. PRE-ADJUSTMENTS AND CHECKS

Connect the apparatus to the mains via a variable transformer. Then measure the mains current at 220 V, 50 c/s. This should not exceed 600 mA.

- Check that B19 strikes at a mains voltage of 198 V (with the adaptor set to 220 V).
- Restore the mains voltage to 220 V and measure the voltage at the cathode of B19. This should be $-150\text{ V} (\pm 2\text{ V})$ for $\pm 10\%$ mains voltage variation. If necessary, adjust with R213. The ripple may not exceed $15\text{ mV}_{\text{p-p}}$. If necessary select another value for R206.
- Measure the voltage at the junction C61-R218. This should be $-770\text{ V} (\pm 2\%)$ for $\pm 10\%$ mains voltage variation. If necessary, adjust with R232. At $+ \text{ or } -10\%$ mains voltage, the ripple may not exceed $1\text{ V}_{\text{p-p}}$.
- Measure the voltage across C52. This should be between 235 V and 245 V for $\pm 10\%$ mains voltage variation. At this voltage variation the ripple may not exceed $120\text{ mV}_{\text{p-p}}$.
- Check that the voltage at the junction R118 and R117 is 0 V. If necessary, adjust with R115.
- Check that the time-base can function both free-running and triggered. If necessary, adjust R159 and R170.
- Check that the time-base starts at a trace height of about 1 cm with R9 in the mid-position. If necessary adjust R137.
- Check that the voltage at the emitter of TS3 is $-6.3\text{ V} (\pm 0.1\text{ V})$. Maximum variation is 20 mV for 10% mains variation. If necessary adjust with R65. The ripple may not exceed $2\text{ mV}_{\text{p-p}}$.

B. CATHODE-RAY TUBE CIRCUIT

1. Flyback suppression

- Check that for all time-base settings the line has even brightness over the whole length. At medium brightness the flyback should not be visible. If necessary, select another value for C35. (This is best determined in position "200 μ s/cm".)
- With control "INTENS." set at about "3" no trace should be visible. If necessary, select another value for R111.

2. Barrel and pin-cushion distortion

- Produce a picture 50 \times 50 mm at the screen centre. If severe distortion is evident select another value for R69.

3. Focus and astigmatism

- Set switch " $\wedge \vee$ " at "50 Hz".
- Connect a sinusoidal voltage of mains frequency to socket "Y AMPL." to obtain a circle of 4 cm diameter on the screen.
- Using "FOCUS" and "ASTIGM.", it must be possible to adjust the trace so that it is sharp and uniformly thick at minimum brightness.
- Instead of a circle this check may also be carried out with a number of sine waves (about one per centimetre).

C. VERTICAL AMPLIFIER

1. Balance

- Set switch "NORMAL - 2 mV" to "NORMAL" and use control " \downarrow Y \uparrow " to make trace visible.
- Check that when the continuous control "Y AMPL." is turned the line does not shift. If necessary, adjust with R38 and R13 (for fine adjustment, R13 should be at about mid-position.)
- If this is inadequate, set " \downarrow Y \uparrow " to the mid-position and select another value for R44 so that the line is in the middle of the screen. Finally readjust R13 and R38.

2. Hum

- Set switch "NORMAL - 2 mV" to "2 mV".
- Set the continuous control "Y AMPL." to "CAL."
- Short-circuit the input "Y AMPL."
- Check that the hum does not exceed 0.5 mm and that with repetitive short-circuiting the line does not jump more than 2 mm.
- If necessary, replace valve B1.

3. Sensitivity

- Set switch "Y AMPL." to "10 mV/cm" and continuous control "Y AMPL." to "CAL".
- Set switch "NORMAL - 2 mV" to "2 mV" and switch "AC/DC" to "DC".
- Connect a square-wave voltage of $8 \text{ mV}_{\text{p-p}}$ (frequency 50 c/s to 1.5 kc/s) to input "Y AMPL.". The trace height should be 4 cm. If necessary, adjust with R49.
- Set switch "NORMAL - 2 mV" to "NORMAL".
- Connect a square-wave voltage of $40 \text{ mV}_{\text{p-p}}$ to input "Y AMPL.". The picture height should be 4 cm. If necessary, select another value for R34.

4. Attenuator

- Set switch "NORMAL - 2 mV" to "NORMAL" and continuous control "Y AMPL." to "CAL".
- Check the attenuator by connecting calibrated square-wave voltages (resp. 80 - 200 - 400 - 800 $\text{mV}_{\text{p-p}}$, etc., freq. 50 to 1500 c/s) to input "Y AMPL." and check that the trace height remains at $4 \text{ cm} \pm 1 \text{ mm}$.

5. Control and shift

- Set continuous control "Y AMPL." to "CAL".
- Connect an alternating voltage high enough to give a deflection of 30 cm (frequency 1 to 5 kc/s) to input "Y AMPL.". It should be possible to make the undistorted peaks of the wave form visible, with control " $\downarrow Y \uparrow$ ", within $\pm 2 \text{ cm}$ of the screen centre.

6. Control range of continuous control "Y AMPL."

- Set switch "NORMAL - 2 mV" first to "NORMAL" then to "2 mV". The control range should be from 1 : 2.6 to 1 : 4 and 1 : 5 to 1 : 6 respectively.

7. Square-wave response and amplitude characteristics

- First set switch "NORMAL - 2 mV" to "NORMAL" and switch "Y AMPL." to "10 mV/cm".
 - a. - Check the square-wave response at 5 kc/s. No overshoot should

occur. If necessary adjust with C9. The response should at least be as good as in Fig. 9a.

- Check that the same response occurs in all the attenuator positions. If necessary, adjust this response using the trimmers listed in the following table. The recommended sequence should be observed:

<i>Attenuator position</i>	<i>Trimmer</i>
2 mV	-
20 mV	C11
50 mV	C72
100 mV	C1
200 mV	C71
500 mV	C74
1 V	C3
2 V (screen)	-
5 V (screen)	-
10 V	C5
20 V (screen)	-
50 V (screen)	-

- b. - Set switch "Y AMPL." to "10 mV/cm", continuous control "Y AMPL." to "CAL.".
- Connect a sinusoidal voltage to input "Y AMPL." and check the amplitude characteristic at the following frequencies (constant input signal). Switch "NORMAL - 2 mV" at:

<i>"NORMAL"</i>	<i>"2 mV"</i>
1.5 kc/s - 100%	1.5 kc/s - 100%
0.3 Mc/s \geq 70%	100 kc/s \geq 75%

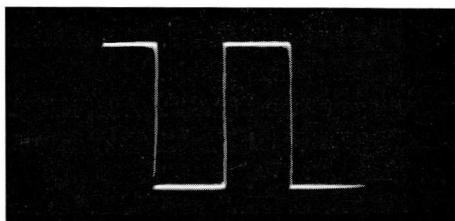

Fig. 9. Response curve

D. CALIBRATION VOLTAGES

- Set switch "Y AMPL." to 10 mV/cm and "AC/DC" to "DC".
 - Connect the output of socket "CAL." to input "Y AMPL.".
- Trace height should be 4 cm \pm 1%. If necessary, adjust by selection of other values for R226 and R233.

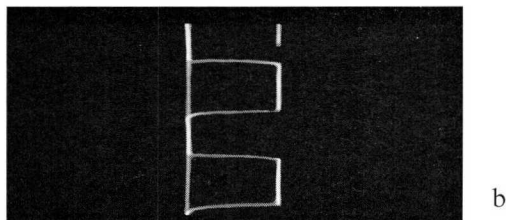

Fig. 9. Response curve

E. HORIZONTAL AMPLIFIER

1. Sensitivity

- Set switch "X DEFL." to "EXT." and continuous "X DEFL." control to "CAL.".
 - The sensitivity of the X amplifier should be 1 V_{p-p}/cm \pm 10%. If necessary adjust with R98.
- The attenuation at 1.5 kc/s via socket "X AMPL. 10 mV/cm" with continuous "X DEFL." at "CAL." should be 8 to 12 times.

2. Shift and linearity

- Set switch "X DEFL." to " \sim ", continuous control "X DEFL." to " $5\times\sim$ ", switch " \sim " to "2 ms/cm" and continuous control " \sim " to "CAL.". Vary control " $\leftarrow X \rightarrow$ ". It should be possible to make both ends of the time-base line visible.
- Connect a time-base voltage to the input "Y AMPL." and a square-wave voltage to socket "X DEFL. 1 V/cm" (frequency 100 kc/s and switch "X DEFL." at "EXT.").
- With continuous control "X DEFL." at "CAL." check for good reproduction with no overshoot. If necessary, select another value for C24. The response should at least be as good as in Fig. 9b.

3. Amplitude characteristic



- For constant input voltage the characteristics should be as follows:
 - 1.5 kc/s - 100%
 - 300 kc/s \geq 70%

4. Deflection length

- Set switch "X DEFL." to "50 Hz".
With continuous control "X DEFL." fully clockwise, the horizontal deflection should be at least 5 cm, and when fully anti-clockwise, less than 2 mm.

F. TIME-BASE GENERATOR

1. Preliminary

First set switch "X DEFL." to "", continuous "X DEFL." to "CAL.", switch " to "200 μ s/cm", switch "TRIGG." to "+HF" and continuous " to "CAL.".

- a. - Connect a sinusoidal voltage, frequency 1.5 kc/s, to input "Y AMPL.".
 - Adjust "TRIGG.-LEVEL." and "TRIGG.-STAB." so that the time-base triggers at a trace height of 4 mm.
 - When switching over from "+" to "-HF", "TRIGG.-LEVEL" should not need to be re-adjusted in order to trigger the time-base. If necessary, adjust R137.
- b. - With "TRIGG.-LEVEL" in the position determined in a), and with cut-out time-base, check that the voltage on junction R177-R189 amounts to $61 \text{ V} \pm 1 \text{ V}$. If necessary select another value for R177.
 - With "TRIGG.-STAB." in mid-position and input voltage as in a), the time-base generator should work in the triggered mode and the line should be 8 cm long. If necessary, adjust R159 and R170 at the same time.
 - The saw-tooth voltage on BU8 should be 39-45 V.
 - With "TRIGG.-STAB." fully clockwise, the time-base should not cut out; when fully anti-clockwise the time-base should cut out, even with a trace height of 6 cm.

2. Internal triggering

First set switch "TRIGG." to "+HF" and adjust switch " so that there are a few sine waves on the screen.

- a. - At 50 c/s and 300 kc/s the time base should trigger at a picture height of 4 mm.
- b. - With "TRIGG." at "+HF" triggering should take place on the positive-going edge of the input signal and at "-HF" on the negative-going edge.
- c. - When the time-base sweep time is varied no double traces should appear.
- d. - With switch "TRIGG." in the positions "+LF" and "-LF" at 4 c/s the time base should trigger, at a trace height of 4 mm, on the positive and negative-going edges respectively (Switch "DC-AC" in position "DC").

3. External triggering

- Switch "TRIGG." at "+HF".
- Connect a voltage of $0.9 V_{p-p}$ to socket "EXT. TRIGG." (derived from the same source as the voltage at input "Y AMPL.").
- At 300 kc/s the time-base should trigger.
Set "TRIGG." to "+LF" the time-base should trigger at a frequency of 4 c/s (at a voltage of $0.9 V_{p-p}$).

4. Triggering with mains frequency



- Set switch "TRIGG." to "50 Hz".
- Connect a sinusoidal voltage of mains frequency to input "Y AMPL.".
- The trace should be made stationary by adjusting "TRIGG.-LEVEL" and "TRIGG.-STAB.".
- When switching from "+50 Hz" to "-50 Hz", the trace should shift half a period and then remain stationary.





5. Triggering level

- With internal triggering, "TRIGG.-LEVEL" fully clockwise and a trace height of 8 mm the time-base should just cut out.
- With internal triggering, "TRIGG.-LEVEL" fully anti-clockwise and a trace height of 20 mm the time-base should not cut out. Check at 1.5 kc/s.
"TRIGG.-STAB." should be set for max. trigger sensitivity throughout.

6. Adjustment of the sweep times

First set continuous “” to “CAL.”.

- a. Set continuous “X DEFL.” to “ $\times 1$ ”, “TRIGG.” to “+ or -HF”, “” to “200 $\mu\text{s}/\text{cm}$ ” and continuous control “” to “CAL.”.
 - Connect a sinusoidal or square-wave voltage (frequency 5 kc/s) to input “Y AMPL.”.
 - Starting from the second period from the left, 6 periods should be distributed over a screen width of 6 cm. If necessary, adjust R179.
 - Now set “X DEFL.” to “ $\times 5$ ”.

Each period should be 5 cm (± 1 mm) wide.
- b. Set “X DEFL.” to “ $\times 1$ ”, “” to “500 $\mu\text{s}/\text{cm}$ ”.
 - Connect a sinusoidal or square-wave voltage of 5 kc/s to “Y AMPL.”. 15 periods should occupy 6 cm ± 0.6 mm.
 - Now set “” to “1 ms/cm”, change the input to 500 c/s, three periods should occupy 6 cm ± 0.6 mm.
- c. Set “X DEFL.” to “ $\times 1$ ”, “” at “10 $\mu\text{s}/\text{cm}$ ”.
 - Connect a sinusoidal or square-wave voltage of 100 kc/s to “Y AMPL.” and check that 6 periods occur within 6 cm. If necessary, set C25 to the mid-position and adjust C43.
- d. Set “X DEFL.” to “ $\times 1$ ”, “” to “2 $\mu\text{s}/\text{cm}$.” and an input at 500 kc/s to “Y AMPL.”.
 - Check that 6 periods occur in 6 cm. If necessary, adjust C25.
 - Set “X DEFL.” to “ $\times 5$ ” and check that the period width is 5 cm ± 1 mm.
- e. Set “X DEFL.” to “X1”, “” to “2 $\mu\text{s}/\text{cm}$ ”.
 - Check the linearity with an input signal of 500 kc/s.

Period width difference of adjacent periods should be negligible.
- f. Check the sweep times in positions 20 $\mu\text{s}/\text{cm}$ – 2 ms – 20 ms – and 0.2 s/cm. If necessary, adjust by means of potentiometers R178 – R180 – R181 and R182. The frequencies of the input voltages should be 50 kc/s – 500 c/s – 50 c/s and 5 c/s respectively.
- g. Check the range of continuous “”. It should be 1 : 2.5 to 1 : 3.5.
- h. Check the time-base line length at all sweep times.
Requirements: ≥ 7.7 cm and ≤ 8.3 cm.

- i. As a final check the calibrated sweep times must not have a deviation greater than 2.5% ("X DEFL." at " $\times 1$ ").
In positions "EXT." and "50 Hz" of "X DEFL.", regardless of the setting of "TRIGG.-STAB.", the time-base generator should not function. Thus there should be no output at BU8.

7. Brightness modulation

With an input signal of 30 V_{p-p}, frequency 200 c/s, at BU9 (impedance of the voltage source $\leq 30 \text{ k}\Omega$) the brightness modulation should be clearly visible at normal brightness.

8. Mechanical beam-suppression

- Set the time-base generator to free-running. If a plug is inserted into BU9 the time-base line should disappear.
- Connect BU9 to BU10: the line should reappear.

Information on fault-finding



A. MAINS TRANSFORMER TAPPINGS

The available unloaded voltage tapings are listed in the main circuit diagram in the form of a table.

B. VOLTAGES AND WAVEFORMS IN THE APPARATUS

The d.c. voltage levels at the valve electrodes are given in the main circuit diagram and on the relevant printed circuits.

Voltage waveforms in the time-base generator are shown at the relevant points on the printed circuits.

The d.c. voltage values which are indicated in the diagram and on the printed wiring plates have been measured with a d.c. voltmeter, GM 6020. These values may differ slightly in various apparatuses. Hence they are for information purposes only. Values at B8 are measured with R5 anti-clockwise. The waveforms are measured under the following conditions:

- sinusoidal voltage (3 kc/s) at BU1,
- switch SK3 at 100 μ sec/cm.

C. REMARK

Whenever the apparatus is sent to a PHILIPS workshop the following points should be observed:

- carefully pack the apparatus in the original packing, or, if this is not available, a wooden crate.
- describe the fault(s) as fully as possible.
- tie on a label bearing the name and address of the sender.
- send the apparatus direct to the appropriate PHILIPS address, provided by the local organisation.

List of component parts



A. LIST OF MECHANICAL PARTS

Item	Fig.	Number	Description	Code number	S	Minimum stock for number of apparatuses			
						1	3	5	10
1	10	6	Knob	M7 773 53	*	-	1	2	3
2	10	6	Cap with arrow	B1 891 49	**	-	1	2	3
3	10	4	Lamp holder	4822 157 00732	*	-	1	1	1
4	10	1	Text plate	M7 193 08	**	-	-	-	1
5	10	1	Graticule	M7 336 39	*	-	-	-	1
6	10	1	Plate	M7 113 91	*	-	-	-	1
7	10	5	Knob	973/52	*	-	1	2	3
8	10	5	Pointer	973/P55	**	-	1	1	1
9	10	4	Knob	973/58	*	-	1	2	3
10	10	4	Cap with arrow	973/DP54	**	-	1	2	3
11	10	1	Cap without arrow	973/D51	**	-	1	1	1
12	10	2	Connecting terminal	M7 603 89	*	-	-	-	1
13	10	4	Stud	P7 655 14	**	-	-	-	1
14/26	10/12	6	Socket	979/11	*	-	1	2	2
15/29	10/12	2	Switching socket	M7 751 78	*	-	1	1	2
16	10	1	Handle	M7 076 17	**	-	-	-	1
17	10	2	Fastener for handle	E2 742 67	**	-	-	-	1
18	10	2	Sliding switch (SK 5,6)	M7 432 18	*	-	1	1	1
21	11	1	Switch (SK1)	B1 590 33	*	-	1	1	1
22	11	1	Strip	910/18 × 110	**	-	-	-	1
23	13	1	Valve-holder (B15)	P7 655 33	*	1	2	3	5
24	13	2	Feed-through, 500 V	978/D17	*	-	-	-	1
25	12	1	Mains socket	978/M2 × 19	*	-	-	1	1
27	12	1	Fuse holder	974/4 × 50	*	-	-	1	1
28	12	1	Voltage adaptor	M7 737 15	*	-	-	-	1
-	-	1 m	Wire, 15 kV	R 368 KA/05AA0	*	-	-	-	1
-	-	1	Anode contact	B1 885 05	*	-	-	-	1
-	-	1	Switch (SK8)	M7 432 20	*	-	1	1	1
-	-	14	Valve-holder (noval)	976/PW9 × 12	*	1	2	3	5
-	-	38	Fish-spine heads	959/43	**	-	-	-	1

Item	Fig.	Number	Description	Code number	S	Minimum stock for number of apparatuses			
						1	3	5	10
-	-	160	Soldering tag	A3 320 36	**	2	2	4	4
-	-	4	Valve holder (miniature)	976/PW 7×10	*	1	2	3	5
-	-	2	Valve holder B1,2 (miniature)	4822 157 00591	*	1	1	2	3
-	-	1 m	Cable	R 209 KA/11BB0	*	-	-	1	1
-	-	2	Coaxial plug	978/4×65	*	-	-	1	1
-	-	2	Plug	978/1×4AP	*	-	1	1	1
-	-	1	Printed circuit unit A, without components	P8 750 48	*	-	-	-	1
-	-	1	Printed circuit unit D, without components	P8 751 47	*	-	-	-	1
-	-	1	Printed circuit unit J, without components	P8 751 51	*	-	-	-	1
-	-	1	Printed circuit unit L without components	P8 751 52	*	-	-	-	1
-	-	1	Printed circuit unit E, with components	4822 158 00405	*	-	-	-	1
-	-	1	Printed circuit unit F, with components	4822 159 00412	*	-	-	-	1
-	-	1	Printed circuit unit G, with components	4822 158 00408	*	-	-	-	1
-	-	1	Printed circuit unit P, with components	4822 159 00413	*	-	-	-	1

Purpose of the "S" column

Components marked with one asterisk

These components generally have a long or unlimited service-life, but their presence is essential for the correct working of the apparatus. Stocking up of a few of these components depends on the following factors:

- The number of apparatuses present in the country concerned.
- The necessity of having the apparatus working continuously or not.
- The delivery-time of the components with respect to importation into the country concerned and the duration of transport.

Components marked with two asterisks

These components have a long or unlimited service-life and they are not essential for the correct working of the apparatus.











Generally there is no local stock.

B. LIST OF ELECTRICAL PARTS



Note:

Only those components which are not standard are stated in the parts list. The standard parts in the circuit diagrams are indicated with symbols from which the service code number can be derived.

The key to the code is given below:

	Carbon resistor	0.25 W	$\leq 1 \text{ M}\Omega : 5\%$	902/K....
			$> 1 \text{ M}\Omega : 10\%$	
	Carbon resistor	0.5 W	$\leq 10 \text{ M}\Omega : 1\%$	901/....
			$> 10 \text{ M}\Omega : 2\%$	
	Wire-wound resistor	5.5 W	$\leq 270 \ \Omega : 10\%$	938/A....
			$> 270 \ \Omega : 5\%$	
	Wire-wound resistor	10 W	5%	938/B....
	Ceramic capacitor		500–700 V	904/....
	Ceramic "Pin-up" capacitor		500 V	904/P....
	Styroflex capacitor		500 V 1%	905/D....
	Polyester capacitor		400 V 10%	906/....
	Ceramic trimmer			908/....
	Air trimmer (for printed-wiring boards)			908/P....

Example:

	Code number	901/120K
	Code number	904/4E7

All resistors are vaporised carbon resistors, unless otherwise specified. Components indicated with P.W. are specially intended for mounting on printed circuit boards.

Resistors

No.	Code number	Value	Tol. (%)	Power	Description
R1	M7 637 13	30 Ω			Wire-wound potentiometer
R2	916/GE100K	100 $k\Omega$			Potentiometer (lin.)
R3	916/GE2K	2 $k\Omega$			Potentiometer (lin.)
R4	916/GE1M	1 $M\Omega$			Potentiometer (lin.)
R5	916/GE10K	10 $k\Omega$			Potentiometer (lin.)
R7	B1 513 51				Potentiometer (neg. log.)
R8	916/EE100K	100 $k\Omega$			Potentiometer (lin.) with switch
R9/10	E 090 ZZ/03	2×100 $k\Omega$			Double potentiometer (linear)
R11	916/GE100K	100 $k\Omega$			Potentiometer (lin.)
R12	4822 071 00845	100 $k\Omega$			Potentiometer (lin.) with switch
R13	916/GE2K	2 $k\Omega$			Potentiometer (lin.)
R14	B8 305 17D/450K	450 $k\Omega$	1%	0.25 W	
R15	B8 305 23D/55K	55 $k\Omega$	1%	0.1 W	
R16	B8 305 17D/495K	495 $k\Omega$	1%	0.25 W	
R17	B8 305 23D/5K	5 $k\Omega$	1%	0.1 W	
R18	B8 305 17D/500K	500 $k\Omega$	1%	0.25 W	
R19	B8 305 23D/500E	500 Ω	1%	0.1 W	
R20	B8 305 17D/250K	250 $k\Omega$	1%	0.25 W	
R21	B8 305 23D/500K	500 $k\Omega$	1%	0.1 W	
R22	B8 305 17D/400K	400 $k\Omega$	1%	0.25 W	
R23	B8 305 23D/125K	125 $k\Omega$	1%	0.1 W	
R24	B8 305 17D/500K	500 $k\Omega$	1%	0.25 W	
R30	E 003 AG/D47K	47 $k\Omega$	5%	1 W	
R31	E 003 AG/D47K	47 $k\Omega$	5%	1 W	
R38	E 199 AA/B13B 10K	10 $k\Omega$		1 W	Wire-wound potentiometer
R42	E 003 AG/D51K	51 $k\Omega$	5%	1 W	
R43	E 003 AG/D47K	47 $k\Omega$	5%	1 W	
R49	916/GE1K	1 $k\Omega$			Potentiometer (lin.)
R52	E 003 AG/D22K	22 $k\Omega$	5%	1 W	
R53	E 005 AG/D22K	22 $k\Omega$	5%	1 W	
R54	E 003 AG/D3K3	3.3 $k\Omega$	5%	1 W	
R65	E 097 AD/500E	500 Ω			Potentiometer P.W.
R66	E 003 AG/C82K	82 $k\Omega$	5%	1 W	
R95	Y2 110 06	39 $k\Omega$	10%	3 W	Carbon resistor in glass
R98	E 097 AD/1K	1 $k\Omega$			Potentiometer P.W.

R100	B8 305 08B/33K	33 k Ω	5%	2	W	
R101	B8 305 08B/33K	33 k Ω	5%	2	W	
R105	Y2 110 06	39 k Ω	10%	3	W	Carbon resistor in glass
R106	E 003 AG/D8K2	8.2 k Ω	5%	1	W	
R115	E 097 AD/500K	500 k Ω				Potentiometer P.W.
R121	E 003 AG/D4K7	4.7 k Ω	5%	1	W	
R122	E 003 AG/D4K7	4.7 k Ω	5%	1	W	
R134	E 003 AG/D22K	22 k Ω	5%	1	W	
R137	E 097 AD/200K	200 k Ω				Potentiometer P.W.
R151	E 003 AG/D47K	47 k Ω	5%	1	W	
R159	E 097 AD/100K	100 k Ω				Potentiometer P.W.
R160	E 003 AG/D6K8	6.8 k Ω	5%	1	W	
R163	E 003 AG/D100K	100 k Ω	5%	1	W	
R168	E 003 AG/D6K8	6.8 k Ω	5%	1	W	
R170	E 097 AD/1K	1 k Ω				Potentiometer P.W.
R171	B8 305 08B/10K	10 k Ω	5%	2	W	
R178	E 097 AD/10K	10 k Ω				Potentiometer P.W.
R179	E 097 AD/10K	10 k Ω				Potentiometer P.W.
R180	E 097 AD/10K	10 k Ω				Potentiometer P.W.
R181	E 097 AD/10K	10 k Ω				Potentiometer P.W.
R182	E 097 AD/10K	10 k Ω				Potentiometer P.W.
R189	E 003 AG/D39K	39 k Ω	5%	1	W	
R203	930/F8K2	8.2 k Ω	5%	10	W	Wire-wound resistor
R206	930/F8K2	8.2 k Ω	5%	10	W	Wire-wound resistor
R213	E 097 AD/20K	20 k Ω				Potentiometer P.W.
R214	E 003 AG/D12K	12 k Ω	5%	1	W	
R232	E 097 AD/500K	500 k Ω				Potentiometer P.W.

Capacitors

C9	C 005 AA/25E	25 pF				Trimmer
C10	C 435 DF/F800(2 \times)	1600 μ F		25 V		Electrolytic (2 par.)
C11	C 004 FA/20E	20 pF				Trimmer P.W.
C12	AC 8208/8+8	8+8 μ F		350 V		Electrolytic P.W.
C22	AC 8210/16	16 μ F		450 V		Electrolytic
C25	C 005 AA/10E	10 pF				Air trimmer
C48	4822 069 00622(3 \times)	3 μ F	10%			Polyester (3 par.)
C50	903/S100K	100 nF		3400 V		
C51	B1 658 77	22 nF		1300 V		Paper
C52	4822 069 00997	16 μ F		450 V		Electrolytic
C54-52	4822 069 00997	48 μ F		450 V		Electrolytic
C56	AG 8209/16+16	16 μ F		350 V		Electrolytic
C57-56	AG 8209/16+16	48 μ F		350 V		Electrolytic
C60-62	AC 8311/12.5+12.5	12.5+12.5 μ F		500 V		Electrolytic
C61	4822 069 00998	8+8 μ F		500 V		Electrolytic

C63	4822 069 00998	8+8 μ F	500 V	Electrolytic
C69	AC 8605/8	8 μ F	200 V	Electrolytic
C71	C 004 FA/20E	20 pF		Trimmer P.W.
C72	C 004 FA/20E	20 pF		Trimmer P.W.
C74	C 004 FA/20E	20 pF		Trimmer P.W.

Miscellaneous

T1	M7 615 29	Mains transformer
VL1	974/T125	Thermal fuse, 125 °C
VL2	974/V1600	Fuse, 1.6 A
VL3	974/V1000	Fuse, 1 A
LA1-4	6828	Lamp, 6 V, 0.1 A

Valves, transistors, rectifiers, etc.

B1-2	EF94	Pentode	6.3 V	300 mA
B3-4	EF80	Pentode	6.3 V	300 mA
B5	EC92	Triode	6.3 V	150 mA
B6-7	EF80	Pentode	6.3 V	300 mA
B8	ECF80	Triode-pentode	6.3 V	430 mA
B9	ECC88	Double-triode	6.3 V	360 mA
B10	ECF80	Triode-pentode	6.3 V	430 mA
B11	ECC85	Double-triode	6.3 V	435 mA
B12-B14	ECF80	Triode-pentode	6.3 V	430 mA
B15	D10-12GL	Cathode-ray tube	6.3 V	300 mA
B16	EL86	Pentode	6.3 V	760 mA
B17	ECC83	Double-triode	6.3 V	300 mA
B18	EL86	Pentode	6.3 V	760 mA
B19	85A2	Voltage stabilizer		
B20	6BA6	Pentode	6.3 V	300 mA
B21	EAA91	Double-triode	6.3 V	300 mA
TS1	OC44	Transistor		
TS2	OC74	Transistor		
TS3	ASZ16	Transistor		
GR1	OA85	Germanium diode		
GR2	OA31	Germanium diode		
GR3	OA210	Silicon diode		
GR4	V250C40	Rectifier	500 V	40 mA
GR5	V250C40	Rectifier	500 V	40 mA
GR6-9	BY100S	Silicon diode		
GR10	OAZ202	Silicon Zener diode		
GR11-16	BY 100	Silicon diode		
GR17-18	BY 100 S	Silicon diode		
GR19-20	OA211	Silicon diode		

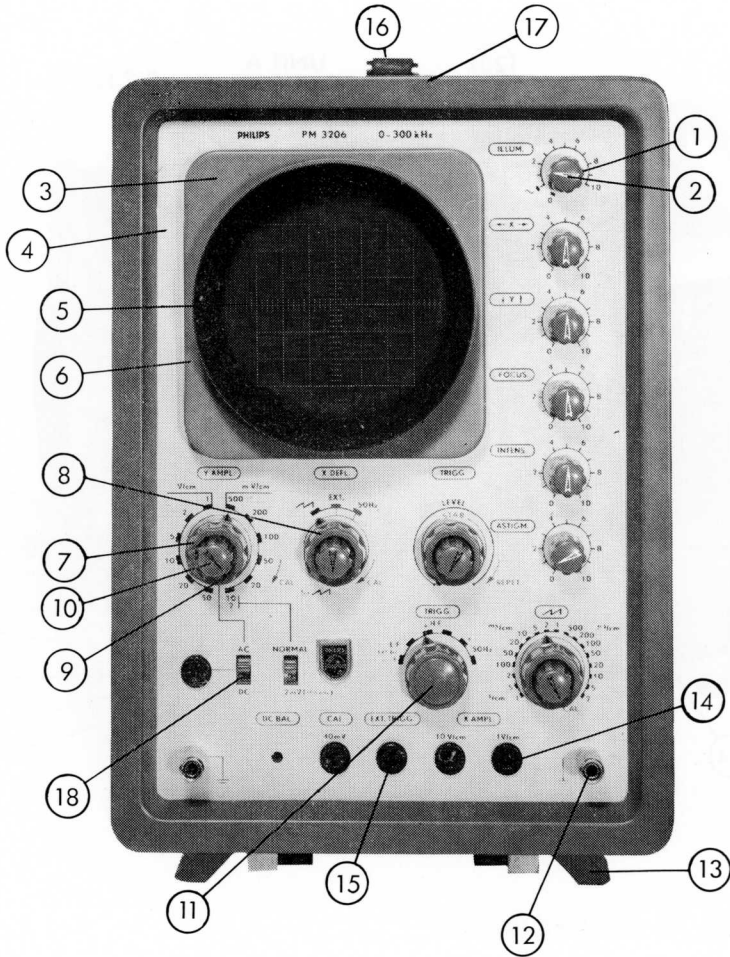

Fig. 10. Front view

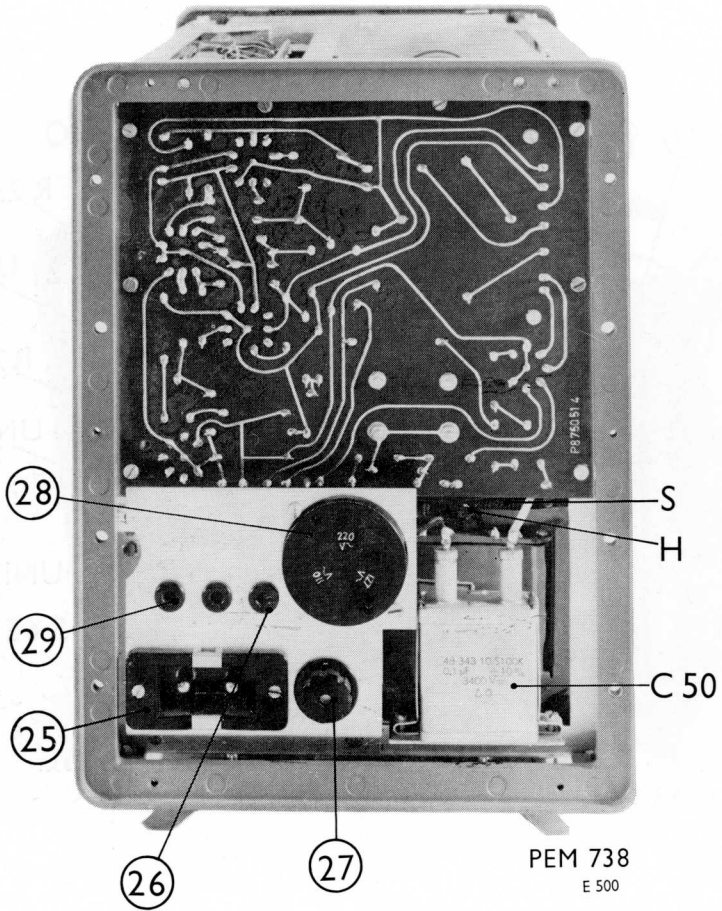

Fig. 12. Rear view

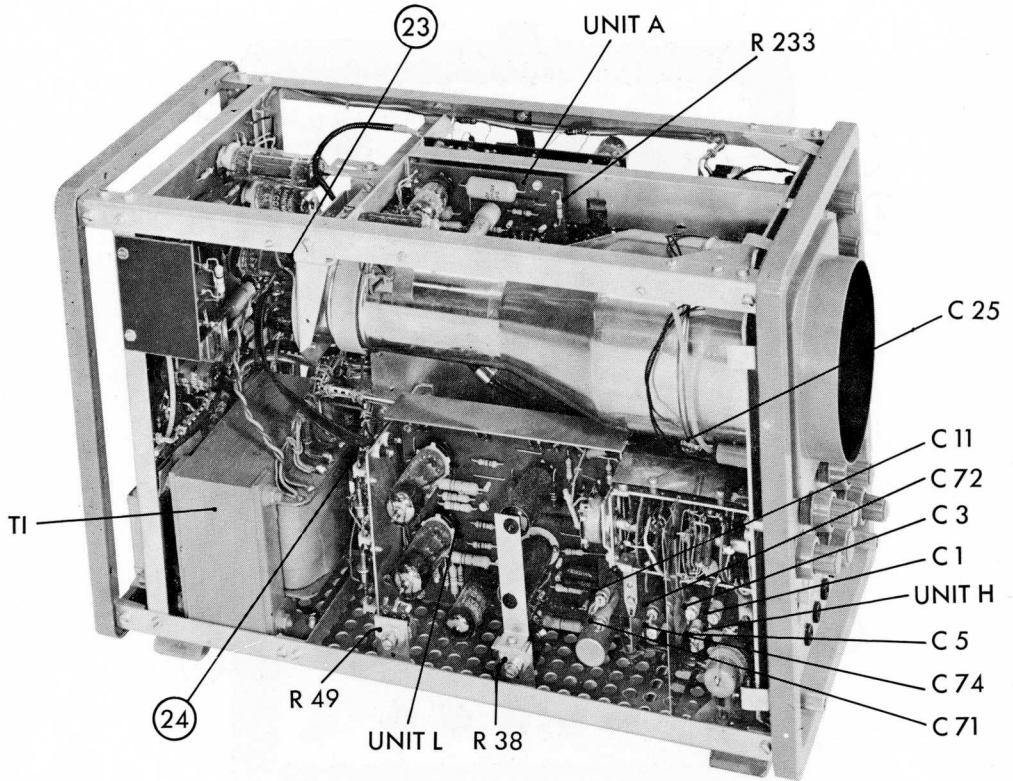

Fig. 13. Left-hand side view

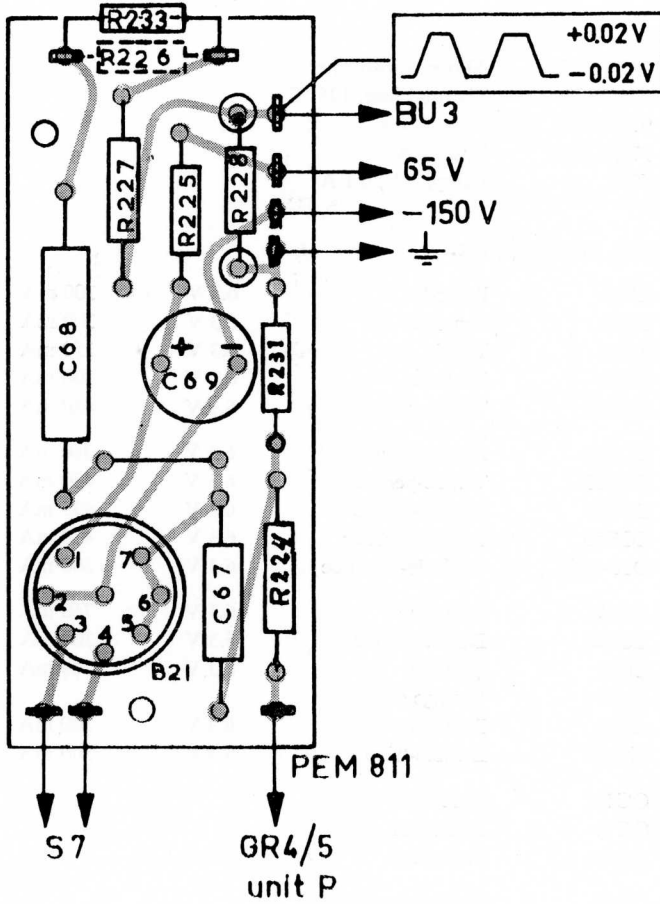

Fig. 14. Printed-wiring board A

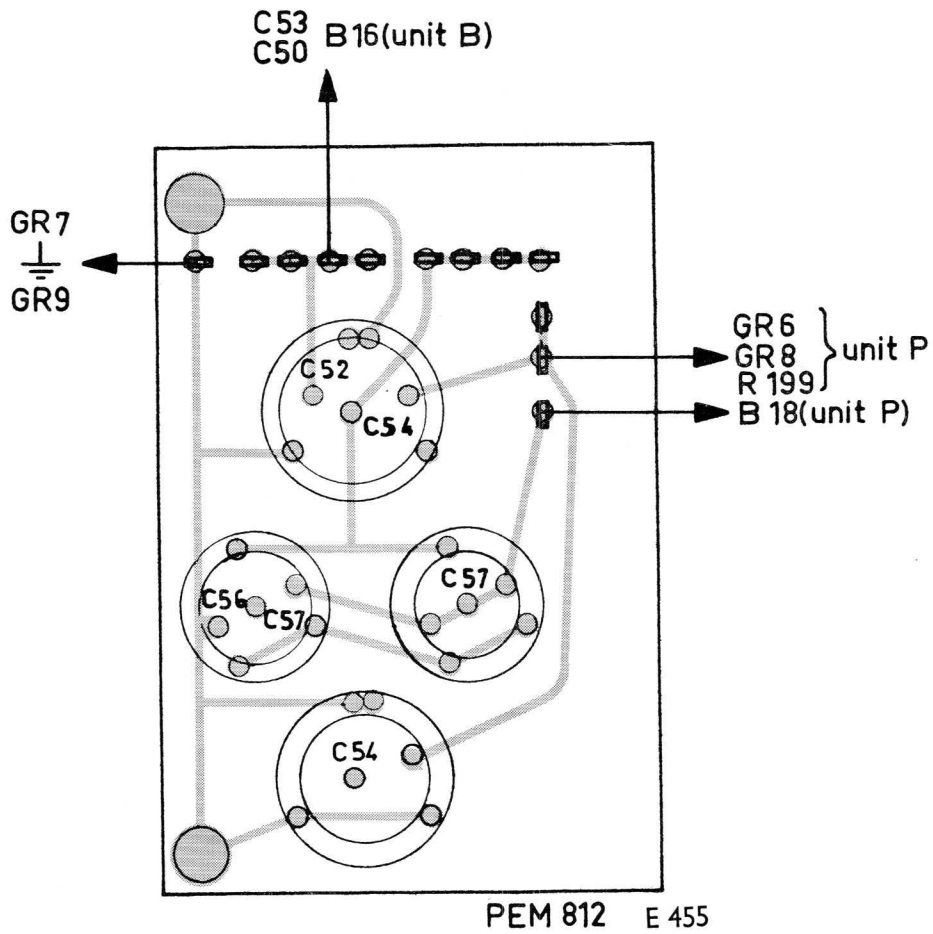

Fig. 15. Printed-wiring board D

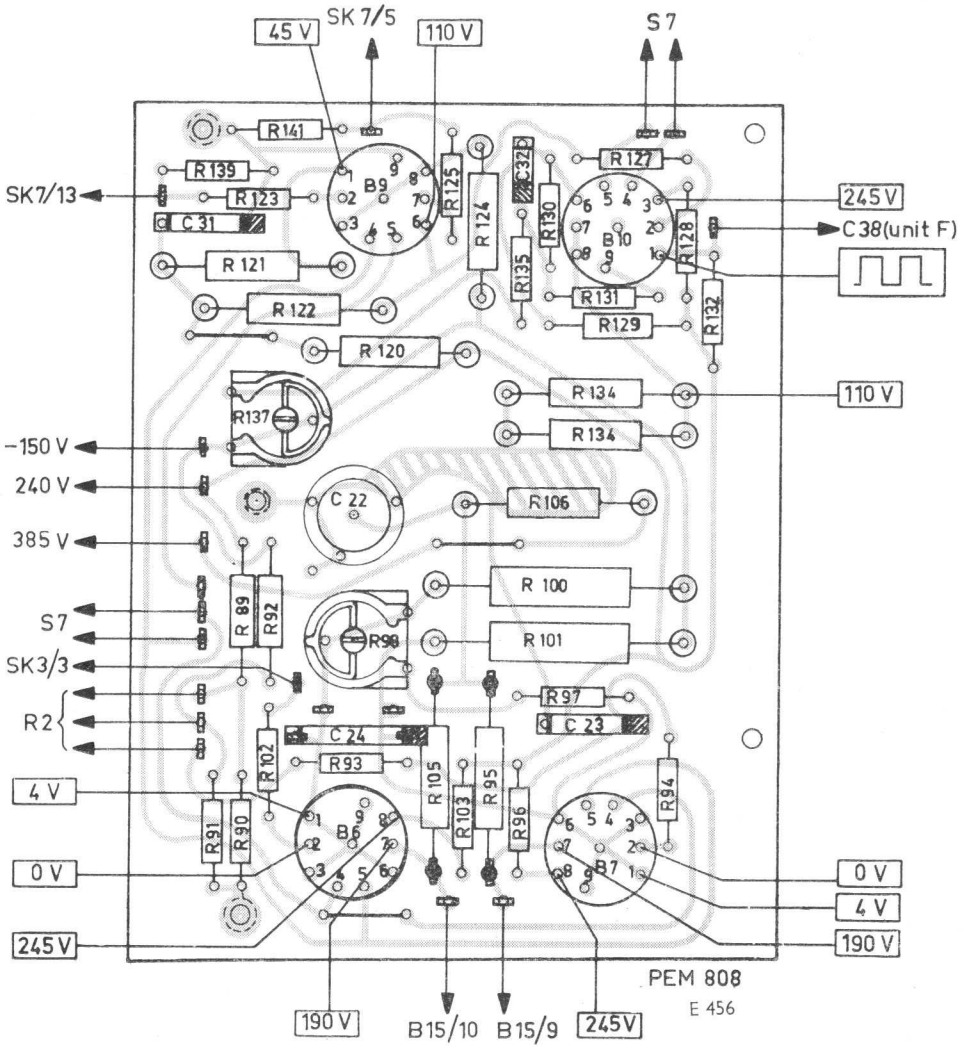

Fig. 16. Printed-wiring board E

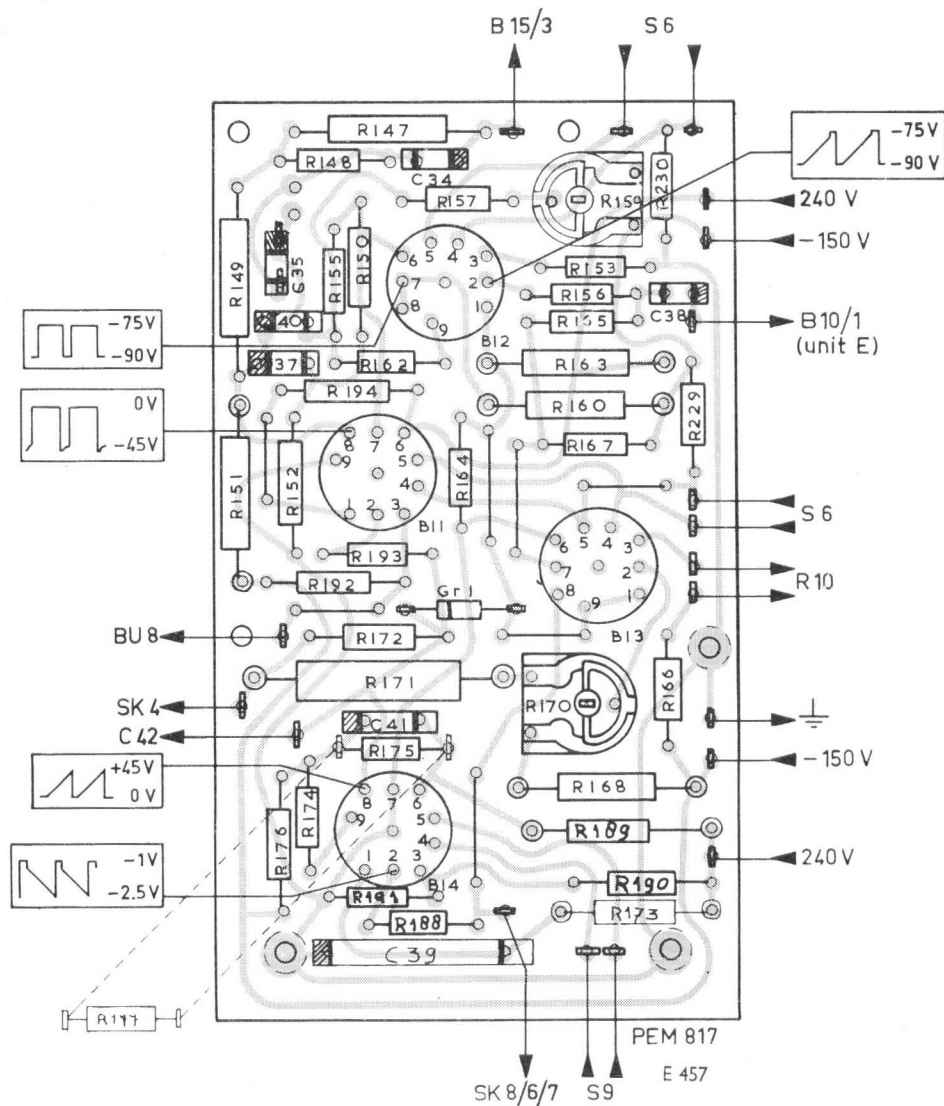

Fig. 17. Printed-wiring board F

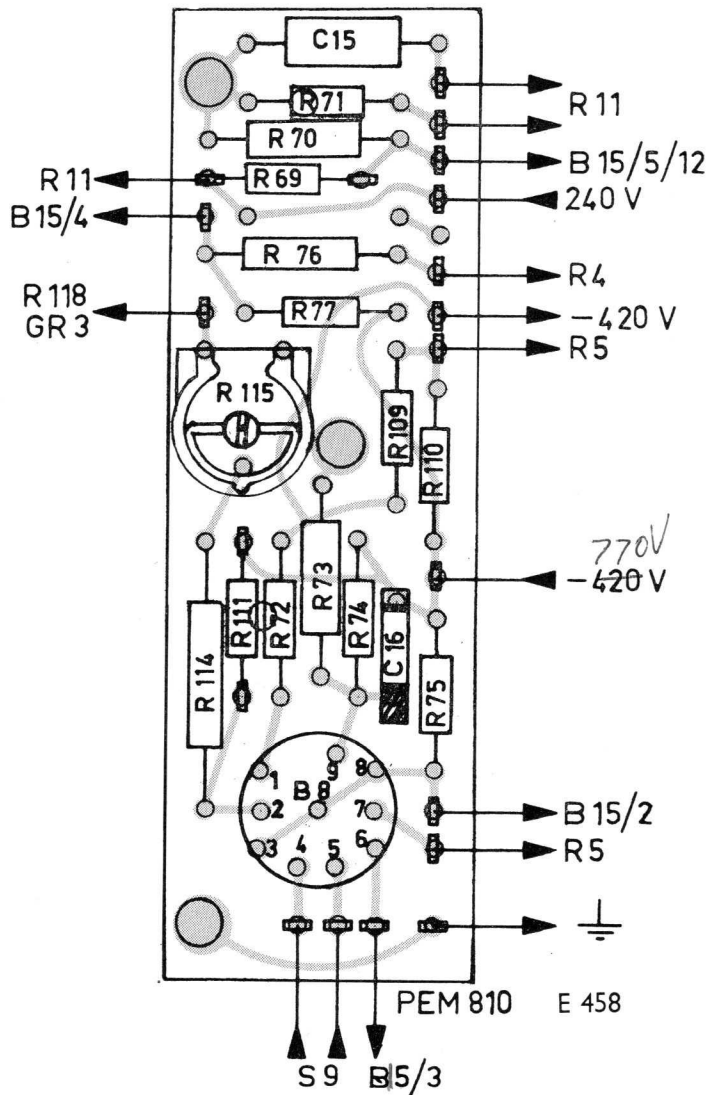

Fig. 18. Printed-wiring board G

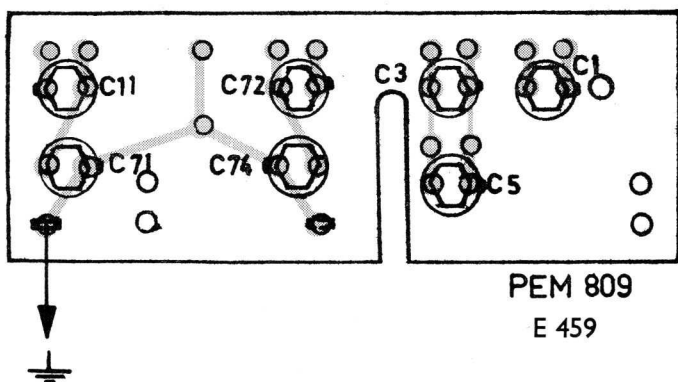

Fig. 19. Printed-wiring board H

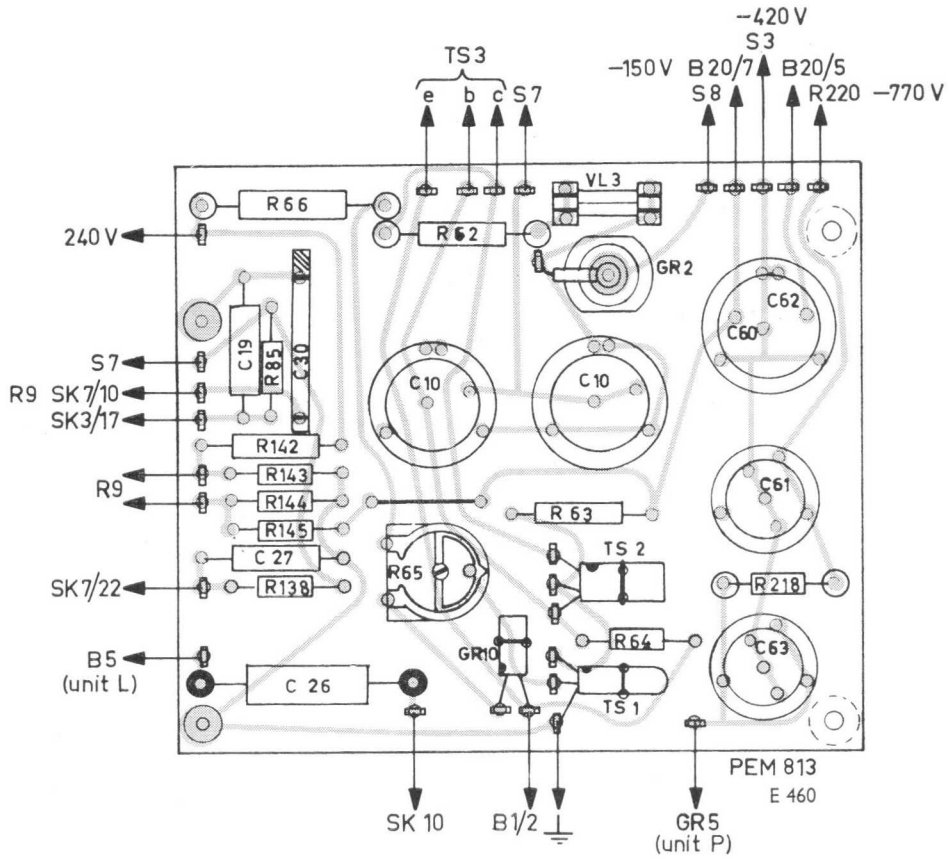

Fig. 20. Printed-wiring board J

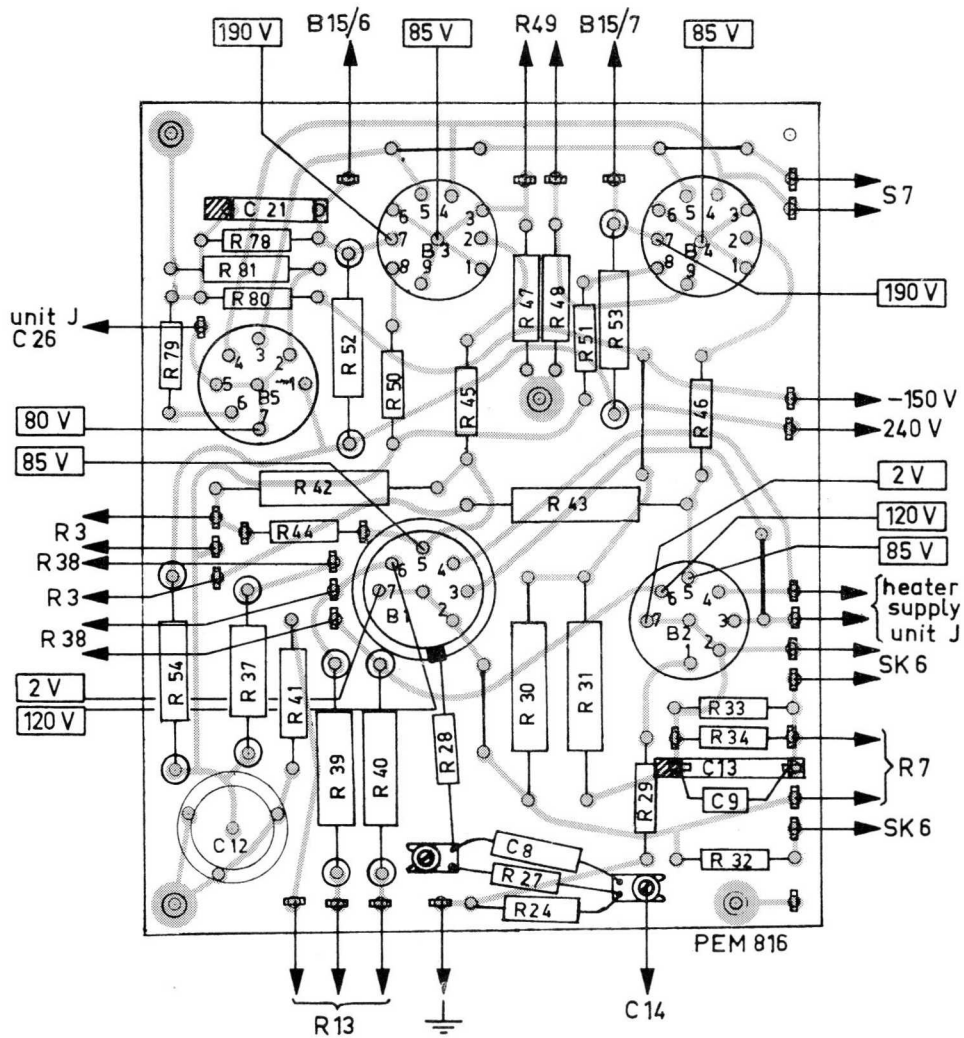

Fig. 21. Printed-wiring board L

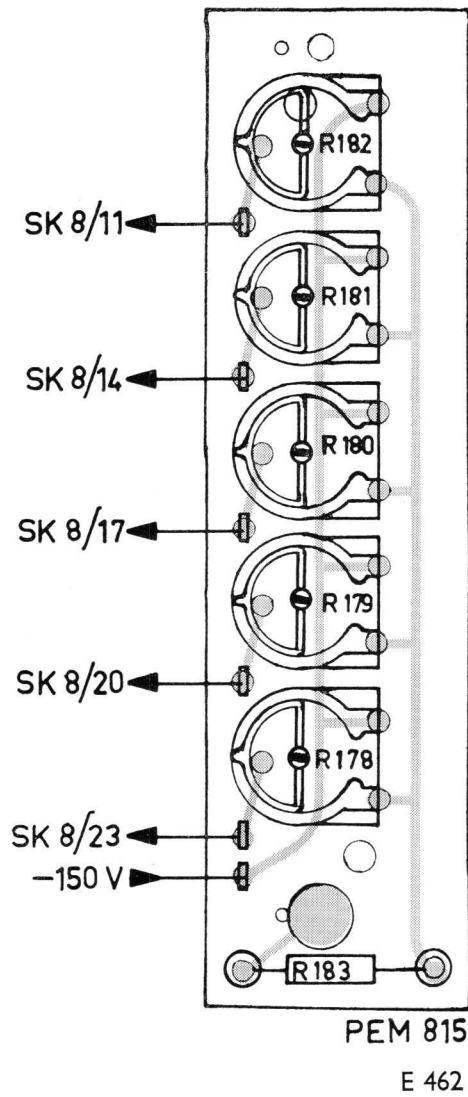

Fig. 22. Printed-wiring board O

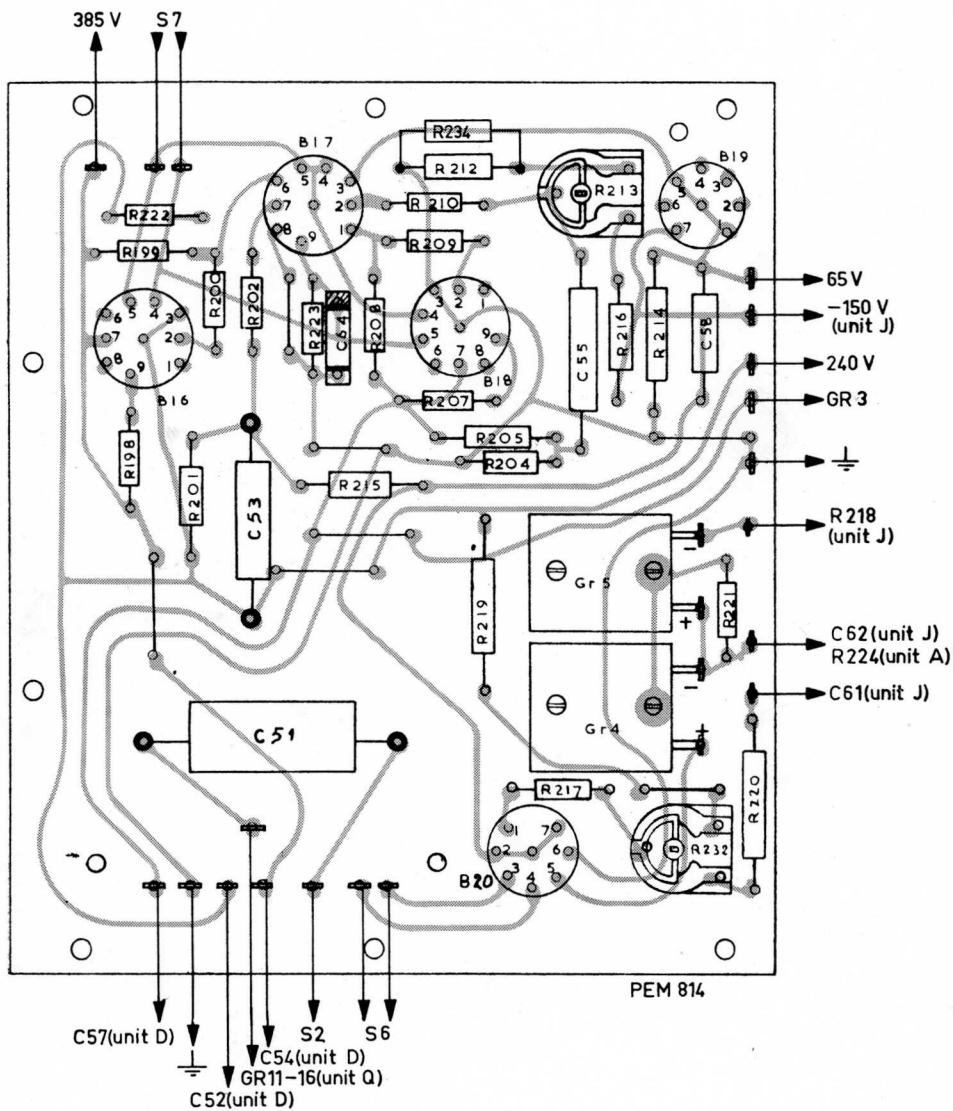

Fig. 23. Printed-wiring board P

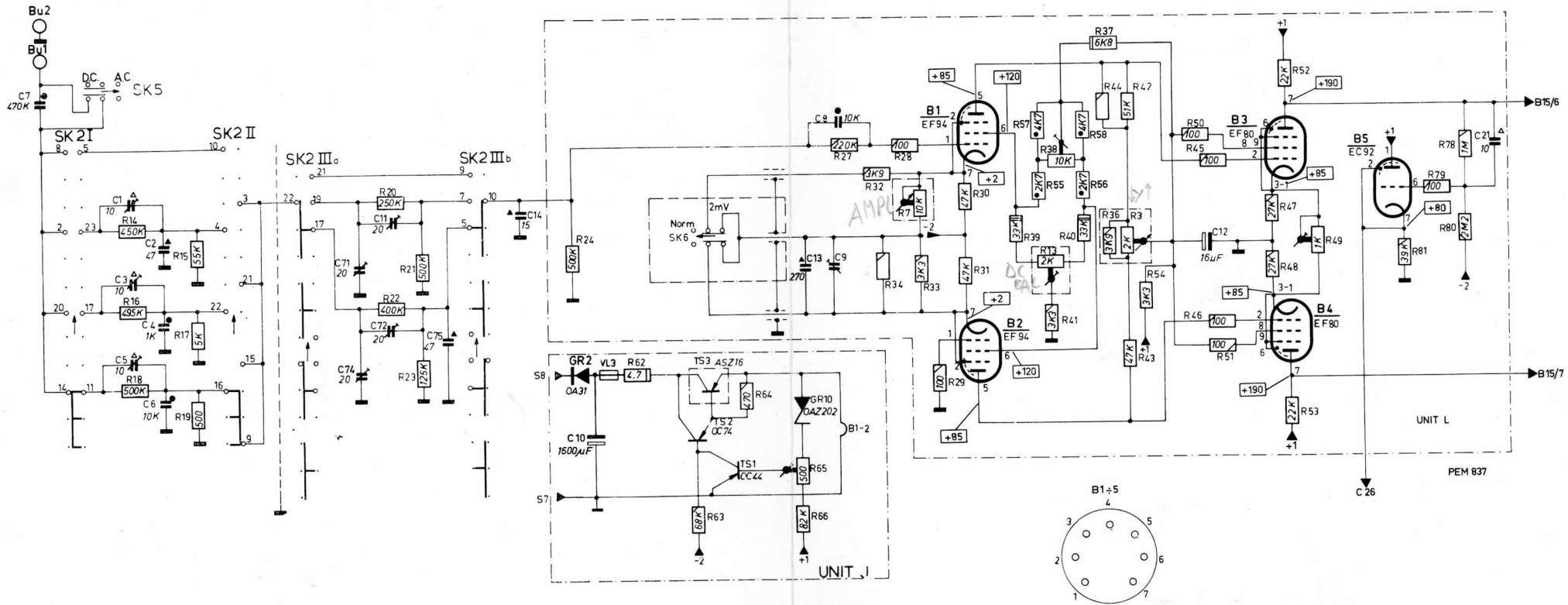

Fig. 24. Y Amplifier

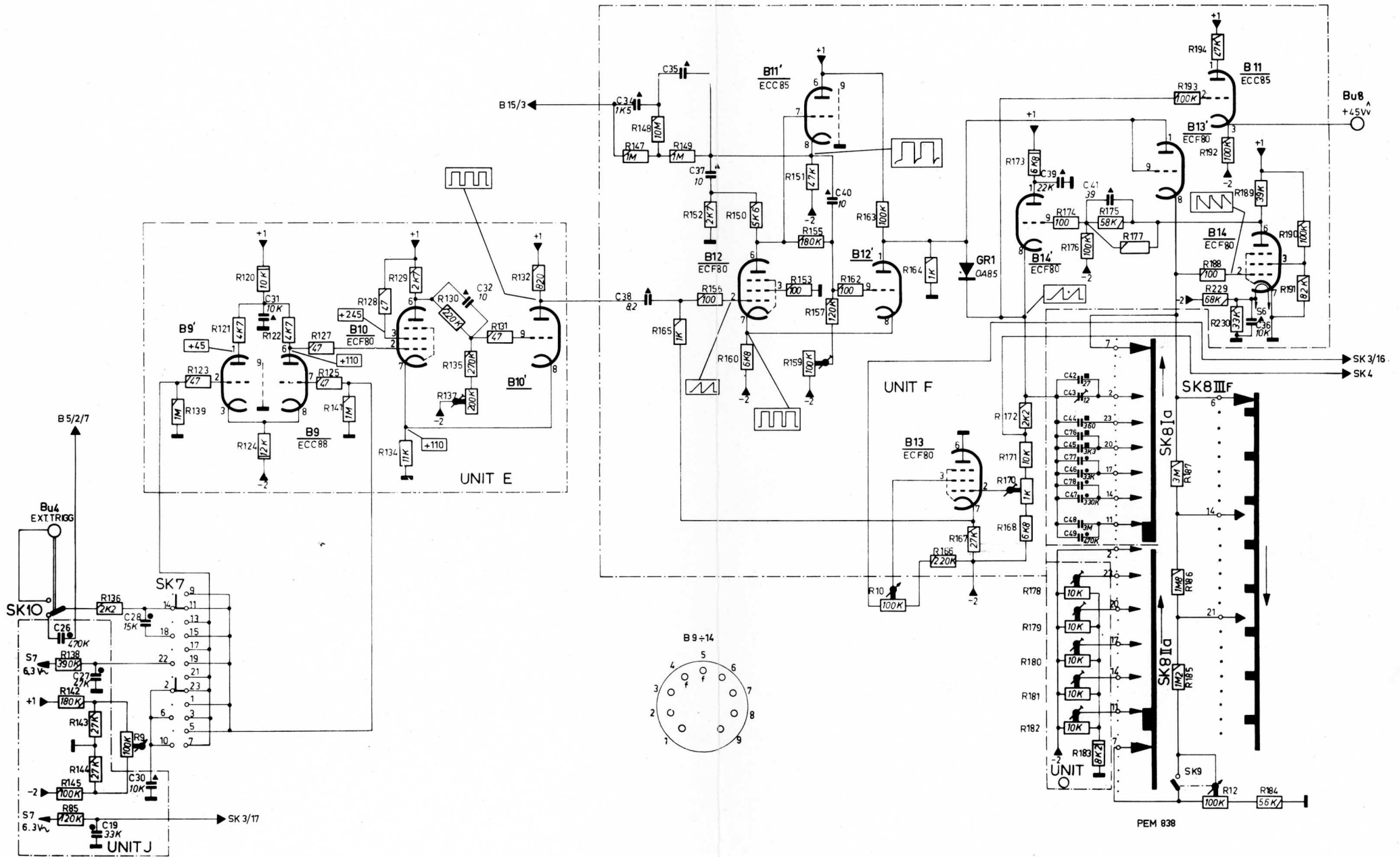

Fig. 25. Time-base generator and trigger pulse shaper

+1 = 250V
 -4 = -770V
 -3 = -420V⁷⁷

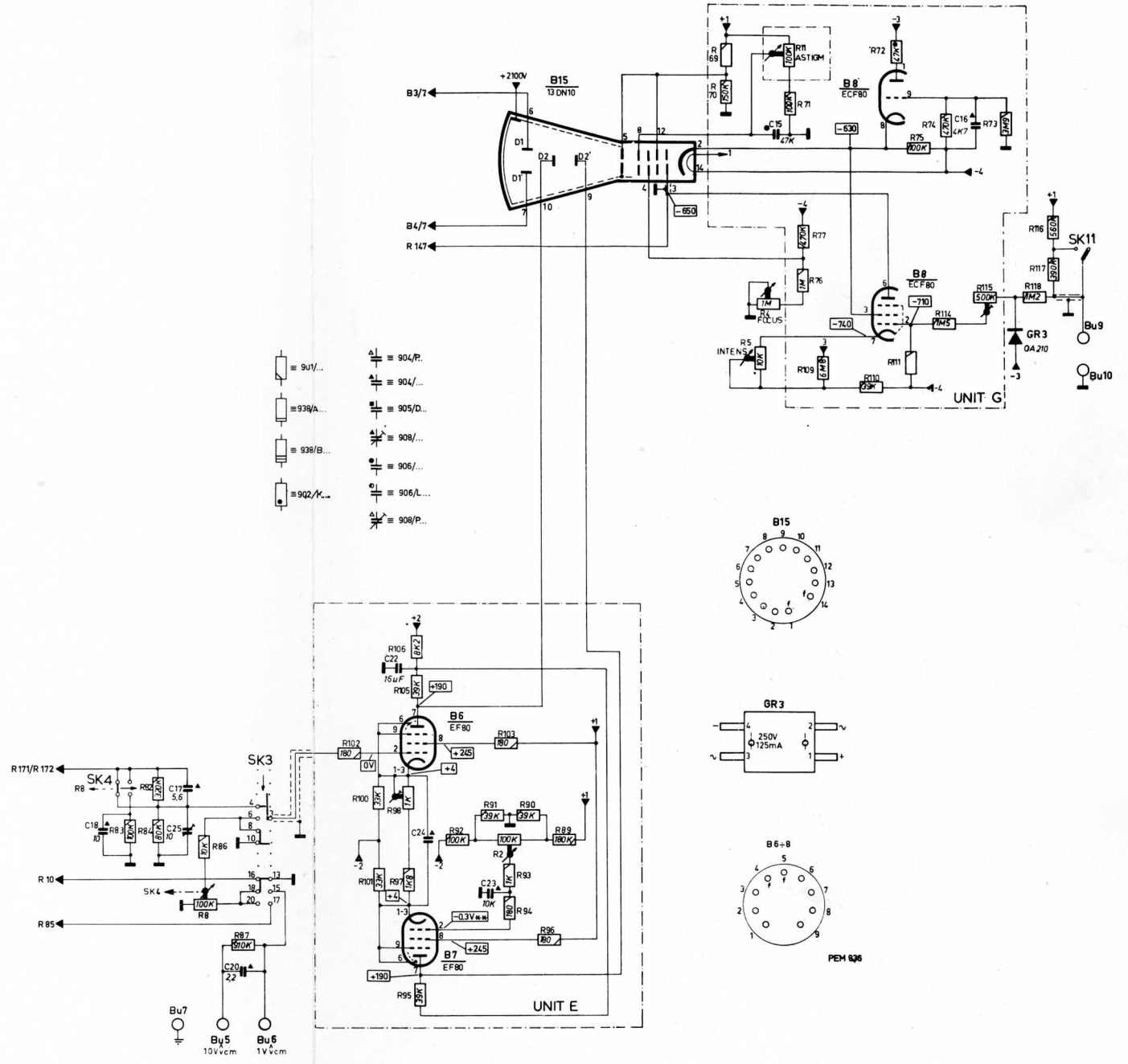

Fig. 26. X Amplifier and cathode-ray tube circuit

Sales and service all over the world

Algérie:	S.A. Philips Nord-Africaine, Immeuble Maurétania, Carrefour de l'Agha, Alger
Argentina:	Philips Argentina S.A., Casilla Correo 3479, Buenos Aires
Australia:	Philips Electrical Ind. (Pty) Ltd., P.O.B. 2703, Sydney
België:	Philips S.A., Keizerinneboulevard 66, Brussel
Belgique:	Philips S.A., 66 Boulevard de l'Impératrice, Bruxelles
Bolivia:	Philips Sudamericana, Casilla 1609, La Paz
Brasil:	Messrs. Inbelsa, Caixa Postal 3159, São Paulo
Canada:	Philips Electronics Ind. Ltd., 116 Vanderhoof Avenue, Toronto 17, Ontario
Chile:	Philips Chilena S.A., Casilla 2687, Santiago de Chile
Colombia:	Philips Colombiana S.A., Communications Department, Apartado Nacional 1505, Bogotá
Costa Rica:	Philips de Costa Rica Ltda., Apartado Postal 4325, San José
Curaçao:	Philips Antillana N.V., Postbus 523, Willemstad
Danmark:	Philips A.S., Prags Boulevard 80, København
Deutschland:	Philips Industrie Elektronik G.m.b.H., Röntgenstrasse 22, Hamburg, Fuhlsbüttel
Ecuador:	Philips Ecuador S.A., Casilla 343, Quito
Egypte:	Philips Orient S.A., Adly Pacha Street 26, Cairo
El Salvador:	Philips de El Salvador, Apartado Postal 865, San Salvador
España:	Philips Ibérica S.A.E., Paseo de las Delicias 65, Madrid
Ethiopia:	Philips Ethiopia Ltd., P.O.B. 659, Addis Abeba
France:	Philips Industrie, S.A., 105 Rue de Paris, Bobigny (Seine)
Great Britain:	M.E.L. Equipment Company Ltd., Instrument House, 207 King's Cross Road, London W.C. 1
Guatemala:	Philips de Guatemala S.A., Apartado Postal 238, Guatemala City
Hellas:	Philips S.A. Hellénique, B.P. 153, Athínai
Hong Kong:	Philips Hong Kong Ltd., P.O.B. 2108, Hong Kong
India:	Philips India Ltd., PIT S./E. Dept., Dugal House, 169 Backbay Reclamation, Bombay 1
Iran:	Philips Iran Ltd., P.O. Box 1297, Teheran
Iraq:	Philips (Iraq) W.L.L., IB/2/35 Masbah, Karradah Al-Sharqiyah, Baghdad
Ireland:	Philips Electrical (Ireland) Ltd., Newstead, Clonskeagh, Dublin 6
Island:	Mr. Snorri P.B. Arnar, P.O. Box 354, Reykjavik
Italia:	Philips S.p.A., Casella Postale 3992, Milano
Liban:	Philips Liban S.A., P.O.B. 670, Beyrouth

Malaya:	Philips Electrical Co. of Malaya Ltd., P.O. Box 1358, Singapore
Maroc:	Société Marocaine Philips S.A. Immeuble Philips, 304 Bld. Mohamed V, Casablanca
Mexico:	Philips S.E.T., Apartado Postal 21420, Mexico 7 D.F.
Nederland:	Philips Bedrijfsapparatuur Nederland N.V., Gagelstraat, Eindhoven
Ned. Antillen:	Philips Antillana N.V., Postbus 523, Willemstad, Curaçao
New Zealand:	Electronic Development and Applications Co. Ltd., 18-20 Lorne St., Wellington
Nigeria:	Philips (Nigeria) Ltd., P.M. Bag 1136, Apapa, Lagos
Nippon:	Industrial Development and Consultant Co., Nikkatsu International Building, Room 420, Tokyo
Norge:	Norsk A.S. Philips, Postboks 5040, Oslo
Österreich:	Philips G.m.b.H., Abt. Industrie, Makartgasse 3, Wien
Pakistan:	Philips Electrical Co. of Pakistan Ltd., Bunder Road, P.O.B. 7101, Karachi
Paraguay:	Philips del Paraguay S.A., Casilla de Correo 605, Asunción
Perú:	Philips Peruana S.A., Apartado Postal 1841, Lima
Polska:	Przedstawicielstwo, Firmy Philips W Polsce, ul Wt. Hibnera 5, Warszawa
Portugal:	Philips Portuguesa S.A.R.L., Rua Joaquim Antonio d'Aguiar 66, Lisboa
Rhodesia:	Philips Rhodesian (Private) Ltd., P.O. Box 994, Salisbury
Schweiz:	Philips A.G., Postfach Zürich 27
South Africa:	South African Philips (Pty) Ltd., P.O.B. 7703, Johannesburg
Suisse:	Philips A.G., Postfach, Zürich 27
Suomi:	Oy Philips Ab, Frederikinkatu 48, Helsinki
Sverige:	Svenska, A.B. Philips, Fack, Stockholm 27
Syrie:	Philips Moyen Orient S.A., P.O.B. 2442, Damas
Taiwan:	Yung Kang Trading Co. Ltd., No. 4 Nam King East Road, 1 Section, P.O. Box 1467, Taipei
Thailand:	Philips Thailand Ltd., 283 Silom Road, Bangkok
Tunisie:	Sté Tunisienne Philips, 32 Bis Rue Lavigerie, Tunis
Turkiye:	Türk Philips Ticaret A.S., Posta Kutusu 504 Istanbul
Uruguay:	Philips del Uruguay, Avda Uruguay 1287, Montevideo
U.S.A.:	Philips Electronics Inc., Special Product Division, 750 South Fulton Avenue, Mount Vernon N.Y.
Venezuela:	C.A. Philips Venezolana, Apartado Postal 1167, Caracas

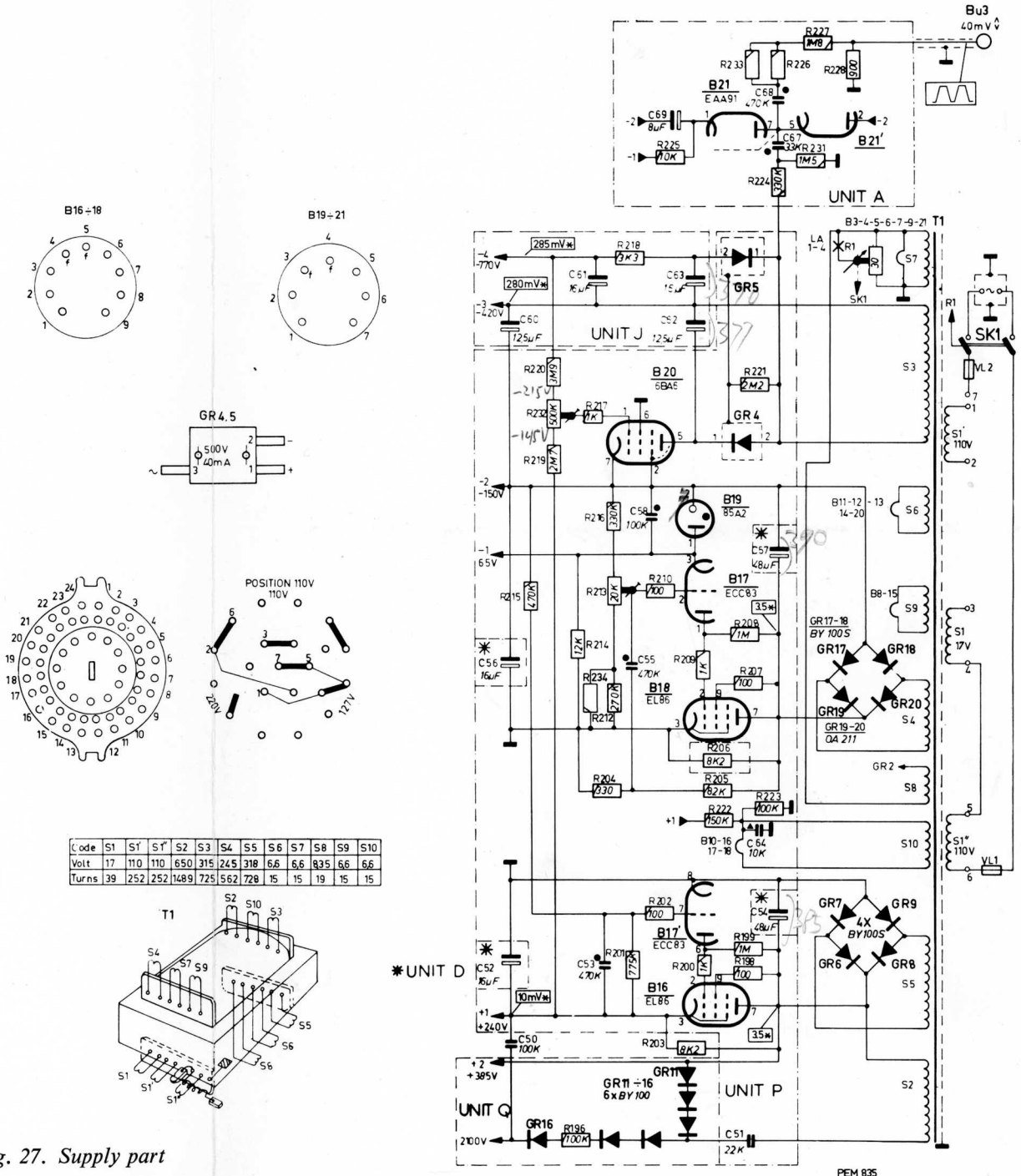

Fig. 27. Supply part

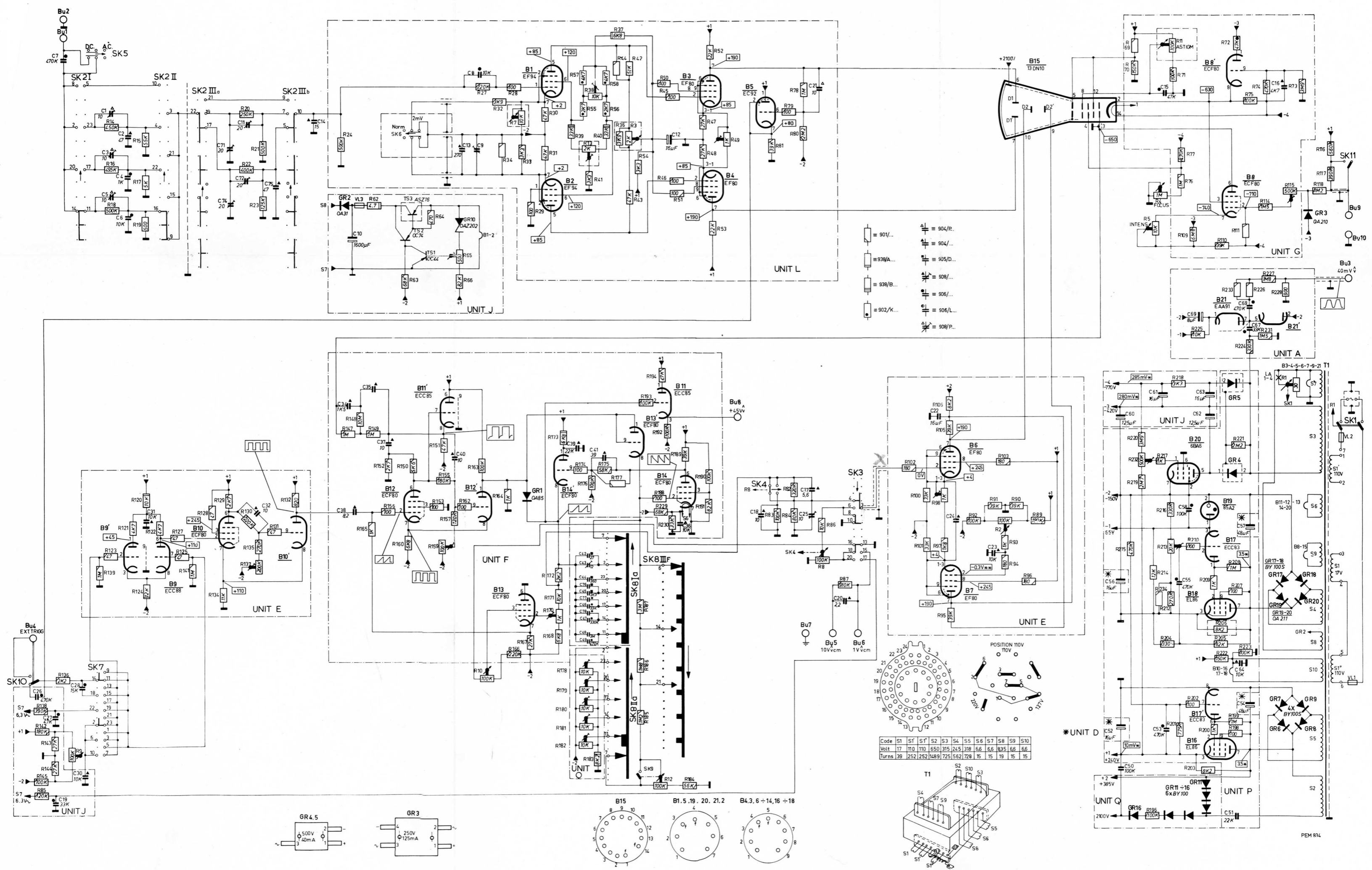

Fig. 28. Circuit diagram