



6816

This bulletin also applies to RCA-6884 which is identical with RCA-6816 except for its heater rating of 26.5 ± 10% volts, 0.52 ampere.

6884

BEAM POWER TUBE

Coaxial-Electrode Structure
Ceramic-Metal Seals
Unipotential Cathode

For Use at Frequencies Up to 2000 Mc
Forced-Air Cooled
180 Watts CW Input Up to 1200 Mc

1.955" Max. Length
1.265" Max. Diameter
Integral Radiator

TENTATIVE DATA

RCA-6816 is a very small, forced-air-cooled beam power tube designed for use as a uhf power amplifier, oscillator, and frequency multiplier as well as an af power amplifier and modulator in compact mobile and fixed equipment. The 6816 has a maximum plate dissipation of 115 watts in modulator service and in cw service. In the latter service, it can be operated with full ratings up to 1200 Mc and is useful at frequencies up through 2000 Mc and above.

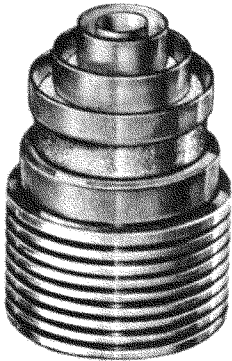

Actual Size

Because of its high power sensitivity and high efficiency, the 6816 can be operated with relatively low plate voltage to give large power output with small driving power.

Featured in the design of the 6816 is a coaxial-electrode structure in which "one-piece" construction combines each electrode, its support, and its gold-plated external contact surface, and in which the respective electrode contact surfaces are insulated from each other by low-loss ceramic bushings. This type of construction facilitates accurate assembly of the electrodes and provides low-inductive, high-conductivity paths to the electrodes themselves.

The coaxial-electrode structure with its ring-type ceramic-metal seals having graduated diameters makes the 6816 particularly useful in either coaxial-cylinder cavity or parallel-line circuits. Its very small size facilitates the construction of compact equipment utilizing grid-drive or cathode-drive circuits.

GENERAL DATA

Electrical:

Heater, for Unipotential Cathode:
Voltage (AC or DC) 6.3 ± 10% volts
Current 2.1 amp
Minimum heating time 60 sec

Mu-Factor, Grid No.2 to Grid No.1 for plate volts = 1000, grid-No.2 volts = 300, and plate ma = 100	16	
Direct Interelectrode Capacitances:		
Grid No.1 to plate*	0.085 max.	μmf
Grid No.1 to cathode & heater	14	μmf
Plate to cathode & heater**	0.015 max.	μmf
Grid No.1 to grid No.2	17	μmf
Grid No.2 to plate	6	μmf
Grid No.2 to cathode & heater**	0.5 max.	μmf

Mechanical:

Mounting Position	Any
Overall Length	1.885" + .070" - .080"
Greatest Diameter	1.250" ± 0.015"
Terminal Connections	See <i>Dimensional Outline</i>
Radiator	Integral part of tube

Air Flow:

Through Radiator--Adequate air flow to limit the plate-seal temperature to 250°C should be delivered by a blower through the radiator before and during the application of plate, grid-No.2, and grid-No.1 voltages. Typical values of air flow directed through the radiator without cowl and with cowl versus plate dissipation are shown in the curves of Figs.1 and 2, respectively. Plate power, grid-No.2 power, and air flow may be removed simultaneously.

To Grid-No.2, Grid-No.1, Cathode, and Heater Seals--A sufficient quantity of air should be delivered to these seals to prevent their temperature from exceeding the specified maximum value of 250°C.

During Standby Operation--Cooling air is not normally required when only heater voltage is applied to the tube.

Seal Temperature (Plate, Grid No.2, Grid No.1, Cathode, and Heater)	250 max.	°C
Weight (Approx.)	2	oz

AF POWER AMPLIFIER & MODULATOR--Class AB₁†

Maximum CCS[®] Ratings, Absolute Values:

DC PLATE VOLTAGE	1000 max.	volts
DC GRID-NO.2 (SCREEN) VOLTAGE	300 max.	volts
MAX.-SIGNAL DC PLATE CURRENT*	180 max.	ma
MAX.-SIGNAL PLATE INPUT*	180 max.	watts
MAX.-SIGNAL GRID-NO.2 INPUT*	4.5 max.	watts
PLATE DISSIPATION*	115 max.	watts

Typical CCS Operation:

Values are for 2 tubes

DC Plate Voltage	650	850	volts
DC Grid-No.2 Voltage [▲]	300	300	volts
DC Grid-No.1 (Control-Grid) Voltage:			
From fixed-bias source	-15	-15	volts
Peak AF Grid-No.1-to-Grid-No.1 Voltage [○]	30	30	volts
Zero-Signal DC Plate Current	80	80	ma
Max.-Signal DC Plate Current	200	200	ma
Zero-Signal DC Grid-No.2 Current	0	0	ma



Max.-Signal DC Grid-No.2 Current	20	20	ma
Effective Load Resistance (Plate to plate)	4330	7000	ohms
Max.-Signal Driving Power (Approx.)	0	0	watts
Max.-Signal Power Output (Approx.)	50	80	watts

Maximum Circuit Values:

Grid-No.1-Circuit Resistance under Any Condition: ^⓪			
With fixed bias	30000	max.	ohms
With cathode bias			Not recommended

AF POWER AMPLIFIER & MODULATOR--Class AB₂[#]

Maximum CCS^⓪ Ratings, Absolute Values:

DC PLATE VOLTAGE	1000	max.	volts
DC GRID-No.2 (SCREEN) VOLTAGE	300	max.	volts
MAX.-SIGNAL DC PLATE CURRENT [*]	180	max.	ma
MAX.-SIGNAL DC GRID-No.1 (CONTROL-GRID) CURRENT [*]	30	max.	ma
MAX.-SIGNAL PLATE INPUT [*]	180	max.	watts
MAX.-SIGNAL GRID-No.2 INPUT [*]	4.5	max.	watts
PLATE DISSIPATION [*]	115	max.	watts

Typical CCS Operation:

Values are for 2 tubes

DC Plate Voltage	650	850	volts
DC Grid-No.2 Voltage [▲]	300	300	volts
DC Grid-No.1 Voltage: From fixed-bias source	-15	-15	volts
Peak AF Grid-No.1-to-Grid-No.1 voltage	46	46	volts
Zero-Signal DC Plate Current	80	80	ma
Max.-Signal DC Plate Current	355	355	ma
Zero-Signal DC Grid-No.2 Current	0	0	ma
Max.-Signal DC Grid-No.2 Current	25	25	ma
Max.-Signal DC Grid-No.1 Current	15	15	ma
Effective Load Resistance (Plate to plate)	2450	3960	ohms
Max.-Signal Driving Power (Approx.) [◆]	0.3	0.3	watt
Max.-Signal Power Output (Approx.)	85	140	watts

LINEAR RF POWER AMPLIFIER--Single-Sideband Suppressed-Carrier Service

Maximum CCS^⓪ Ratings, Absolute Values:

DC PLATE VOLTAGE	1000	max.	volts
DC GRID-No.2 (SCREEN) VOLTAGE	300	max.	volts
MAX.-SIGNAL DC PLATE CURRENT	180	max.	ma
MAX.-SIGNAL DC GRID-No.1 (CONTROL-GRID) CURRENT	30	max.	ma
MAX.-SIGNAL PLATE INPUT	180	max.	watts
MAX.-SIGNAL GRID-No.2 INPUT	4.5	max.	watts
PLATE DISSIPATION	115	max.	watts

Typical CCS Class AB₁ "Single-Tone" Operation:^⓪

Up to 80 Mc

DC Plate Voltage	650	850	volts
DC Grid-No.2 Voltage [▲]	300	300	volts
DC Grid-No.1 Voltage	-15	-15	volts
Zero-Signal DC Plate Current	40	40	ma
Zero-Signal DC Grid-No.2 Current	0	0	ma
Effective RF Load Resistance	2165	3500	ohms
Max.-Signal DC Plate Current	100	100	ma
Max.-Signal DC Grid-No.2 Current	10	10	ma
Max.-Signal DC Grid-No.1 Current	0	0	ma
Max.-Signal Peak RF Grid-No.1 voltage	15	15	volts
Max.-Signal Driving Power (Approx.)	0	0	watts
Max.-Signal Power Output (Approx.)	25	40	watts

Maximum Circuit Values:

Grid-No.1-Circuit Resistance under Any Condition:			
With fixed bias	30000		ohms
With cathode bias			Not recommended

**PLATE-MODULATED RF POWER AMPLIFIER--
Class C Telephony**

Carrier conditions per tube for use with a max. modulation factor of 1.0

Maximum CCS^⓪ Ratings, Absolute Values:

DC PLATE VOLTAGE	800	max.	volts
DC GRID-No.2 (SCREEN) VOLTAGE	300	max.	volts
DC GRID-No.1 (CONTROL-GRID) VOLTAGE	-100	max.	volts
DC PLATE CURRENT	150	max.	ma
DC GRID-No.1 CURRENT	30	max.	ma
PLATE INPUT	120	max.	watts
GRID-No.2 INPUT	3	max.	watts
PLATE DISSIPATION	75	max.	watts

Typical CCS Operation:

At 400 Mc

DC Plate Voltage	400	700	volts
DC Grid-No.2 Voltage ^⓪	200	250	volts
DC Grid-No.1 Voltage [★]	-20	-50	volts
DC Plate Current	100	130	ma
DC Grid-No.2 Current	5	10	ma
DC Grid-No.1 Current	5	10	ma
Driver Power Output (Approx.) [■]	2	3	watts
Useful Power Output (Approx.)	16	45	watts

Maximum Circuit Values:

Grid-No.1-Circuit Resistance under Any Condition	30000	†max.	ohms
--	-------	-------	------

**RF POWER AMPLIFIER & OSCILLATOR--Class C Telegraphy^⓪
and
RF POWER AMPLIFIER--Class C FM Telephony**

Maximum CCS^⓪ Ratings, Absolute Values:

DC PLATE VOLTAGE	1000	max.	volts
DC GRID-No.2 (SCREEN) VOLTAGE	300	max.	volts
DC GRID-No.1 (CONTROL-GRID) VOLTAGE	-100	max.	volts
DC PLATE CURRENT	180	max.	ma
DC GRID-No.1 CURRENT	30	max.	ma
PLATE INPUT	180	max.	watts
GRID-No.2 INPUT	4.5	max.	watts
PLATE DISSIPATION	115	max.	watts

Typical CCS Operation:

At 400 Mc At 1200 Mc

DC Plate Voltage	400	900	900	volts
DC Grid-No.2 Voltage ^⓪	200	300	300	volts
DC Grid-No.1 Voltage ^⓪	-35	-30	-22	volts
DC Plate Current	150	170	170	ma
DC Grid-No.2 Current	5	1	1	ma
DC Grid-No.1 Current	3	10	4	ma
Driver Power Output (Approx.) [■]	3	3	5	watts
Useful Power Output (Approx.)	23	80	40	watts

Maximum Circuit Values:

Grid-No.1-Circuit Resistance under Any Condition	30000	†max.	ohms
--	-------	-------	------

↓ Because the cathode is subjected to considerable back bombardment as the frequency is increased with resultant increase in temperature, the heater voltage should be reduced depending on operating conditions and frequency to prevent overheating the cathode and resultant short life.

* With external flat metal shield having diameter of 6" and center hole 1" in diameter. Shield is located in plane of grid-No.2 terminal, perpendicular to the tube axis, and is connected to grid-No.2 terminal.



- ** With external flat metal shield having diameter of 6" and center hole 3/4" in diameter. Shield is located in plane of grid-No.1 terminal, perpendicular to the tube axis, and is connected to grid-No.1 terminal.
- † Subscript 1 indicates that grid-No.1 current does not flow during any part of the input cycle.
- Continuous Commercial Service.
- ★ Averaged over any audio-frequency cycle of sine-wave form.
- ▲ Preferably obtained from a fixed supply.
- The driver stage should be capable of supplying the No.1 grids of the class AB₁ stage with the specified driving voltage at low distortion.
- The resistance introduced into the grid-No.1 circuit by the input coupling should be held to a low value. In no case should it exceed the specified maximum value. Transformer or impedance coupling devices are recommended.
- # Subscript 2 indicates that grid-No.1 current flows during some part of the input cycle.
- ◆ Driver stage should be capable of supplying the specified driving power at low distortion to the No.1 grids of the AB₂ stage. To minimize distortion, the effective resistance per grid-No.1 circuit of the AB₂ stage should be held at a low value. For this purpose, the use of transformer coupling is recommended.
- "Single-Tone" operation refers to that class of amplifier service in which the grid-No.1 input consists of a monofrequency rf signal having constant amplitude. This signal is produced in a single-sideband suppressed-carrier system when a single audio frequency of constant amplitude is applied to the input of the system.
- Obtained preferably from a separate source modulated along with the plate supply.
- ★* Obtained from grid-No.1 resistor or from a combination of grid-No.1 resistor with either fixed supply or cathode resistor.
- The driver stage is required to supply tube losses and rf circuit losses. It should be designed to provide an excess of power above the indicated values to take care of variations in line voltage, in components, in initial tube characteristics, and in tube characteristics during life.
- ‡ If this value is insufficient to provide adequate bias, the additional required bias must be supplied by a cathode resistor or fixed supply.
- Key-down conditions per tube without amplitude modulation. Amplitude modulation essentially negative may be used if the positive peak of the audio-frequency envelope does not exceed 115% of the carrier conditions.
- ⊕ Obtained preferably from a fixed supply, or from the plate-supply voltage with a voltage divider.
- ⊕⊕ Obtained from fixed supply, by grid-No.1 resistor, by cathode resistor, or by combination methods.

OPERATING CONSIDERATIONS

The *maximum ratings* in the tabulated data for the 6816 are limiting values above which the serviceability of the 6816 may be impaired from the viewpoint of life and satisfactory performance. Therefore, in order not to exceed these absolute ratings, the equipment designer has the responsibility of determining an average design value below each absolute rating by an amount such that the absolute values will never be exceeded under any usual condition of supply-voltage variation, load variation, or manufacturing variation in the equipment itself.

The *maximum seal temperature* of 250°C is a tube rating and is to be observed in the same manner as other ratings. The temperature may be measured with temperature-sensitive paint, such as Tempilaq. The latter is made by the Tempil Corporation, 132 W. 22nd Street, New York 11, N.Y. in the form of liquid and stick.

A suggested *mounting arrangement* for the 6816 is shown in Fig.4 along with a layout of the associated contacts. Flexible connectors are required for the plate, grid-No.2, grid-No.1, cathode, and heater contact surfaces.

Adequate *cooling* of the 6816 is provided in most applications by passing a stream of clean air through the radiator only. A guide to the

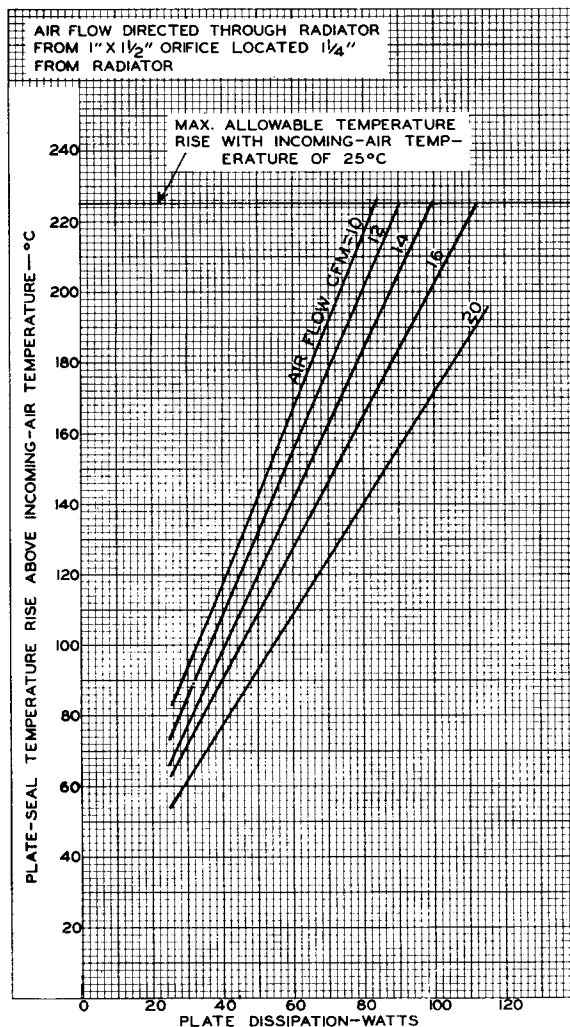

92CM-9220

Fig. 1 - Typical Cooling Requirements for Type 6816 With Air Flow Directed Through Radiator Without Cowling.

required air flow through the radiator for various plate dissipations is given by the curves in Figs. 1 and 2. A recommended arrangement of cowling for the radiator is shown in Fig. 3. Under operating conditions at the higher frequencies or at high ambient temperatures, it may be necessary to direct a stream of air onto the cathode and heater seals, the grid-No.1 seal, and the grid-No.2 seal. In all cases, adequate cooling



air must be provided to prevent exceeding the maximum temperature rating of 250°C for any seal.

The cooling system should be properly installed to insure safe operation of the 6816 under all conditions and for this reason should be electrically interconnected with the plate

The heater of the 6816 should be operated at constant voltage rather than constant current. The rated heater voltage of 6.3 volts should be applied for 60 seconds to allow the cathode to reach normal operating temperature before voltages are applied to the other electrodes. After this warm-up period, the heater voltage should be adjusted as described in the next paragraph.

The unipotential cathode is indirectly heated by the heater, one terminal of which is common to the cathode. The cathode of the 6816 in uhf

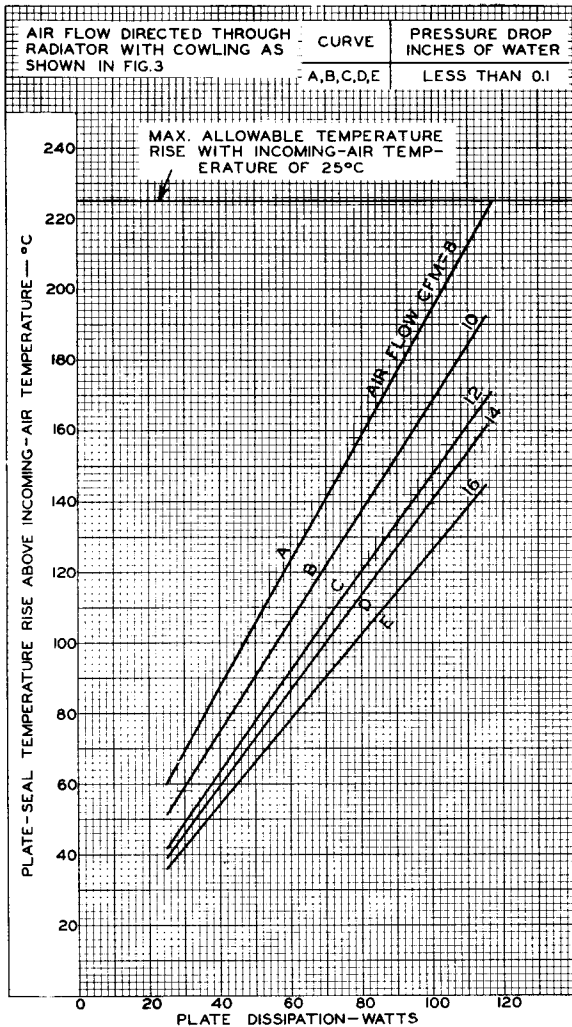

92CM-9219

Fig. 2 - Typical Cooling Requirements for Type 6816 With Air Flow Directed Through Radiator With Cowling.

power supply. Air-flow interlocks which open the power transformer primaries are desirable for protecting the tube when the air flow is insufficient or ceases.

A suitable air filter is required in the air supply. Care should be given to cleaning or replacing the filter at intervals in order that accumulated dirt will not obstruct the required flow of air through the radiator or to the seals.

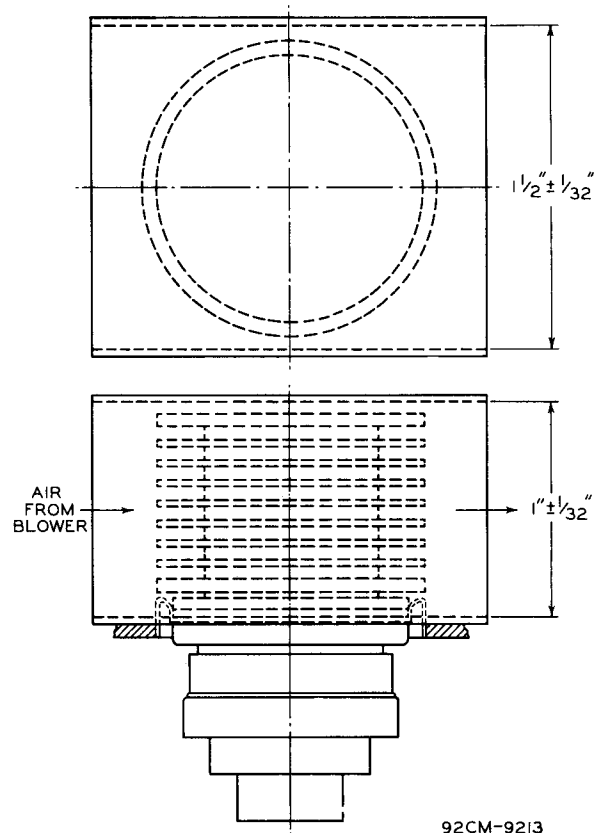

92CM-9213

Fig. 3 - Recommended Cowling for Directing Air Flow Through Radiator of Type 6816.

service is subjected to considerable bombardment resulting from transit-time effects. This back bombardment is a function of the operating conditions and frequency, and must be compensated by reduction of the heater input in order to prevent overheating of the cathode and resultant short life. When long life in continuous service is desired, the 6816 should always be put in operation with full rated heater voltage (6.3 volts) which should then be reduced to the lowest value that will give the desired output.

Grid No. 1 of the 6816 in uhf service is subjected to heating caused not only by the normal electron bombardment as indicated by the grid

current, but also by circulating rf currents. For these reasons, more than ordinary care must be taken during operation to prevent exceeding the grid-No.1 current rating and the maximum grid-No.1 seal temperature rating.

Grid No.2 of the 6816 draws very little current under normal operating conditions. The

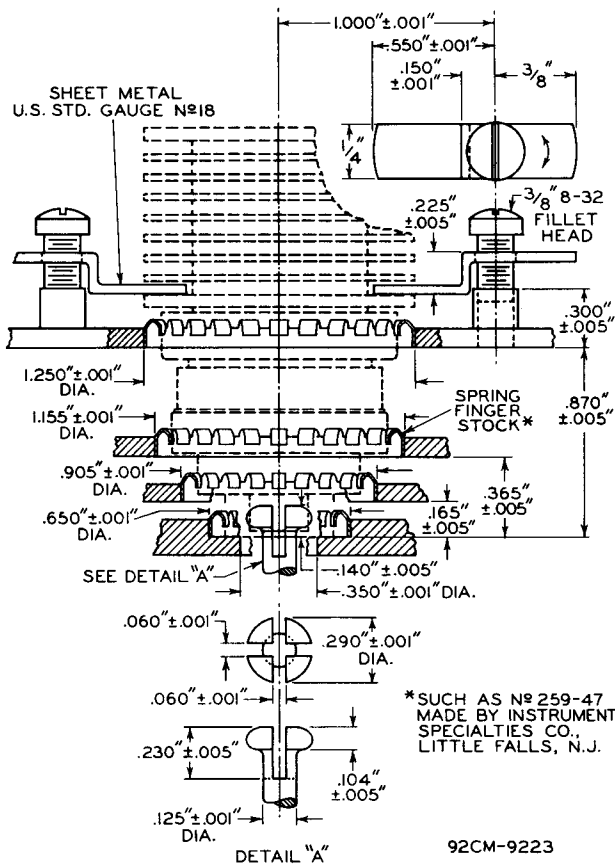

Fig. 4 - Suggested Mounting Arrangement for Type 6816 and Layout of Associated Contacts.

voltage for grid No.2 should be obtained from a source of good regulation. The plate voltage should be applied before or simultaneously with grid-No.2 voltage; otherwise, with voltage on grid No.2 only, its current may be large enough to cause excessive grid-No.2 dissipation. A dc milliammeter should be used in the grid-No.2 circuit so that its current may be measured and the screen dissipation determined.

The grid-No.2 current is a very sensitive indication of plate-circuit loading. When the 6816 is operated without load, the grid-No.2 current rises excessively, often to a value which damages the tube. Therefore, care should be taken when tuning the 6816 circuit under no-load or lightly loaded conditions to prevent exceeding the grid-No.2 input rating of the tube. In this connection, reduction of the grid-No.2 voltage will be helpful.

Protective devices should be used to protect not only the plate but also grid No.2 against overload. In order to prevent excessive plate-current flow and resultant overheating of the tube, the common ground lead of the plate circuit should be connected in series with the coil of an instantaneous overload relay. This relay should be adjusted to remove the dc plate voltage when the average value of plate current reaches a value slightly higher than normal plate current. A protective device in the grid-No.2 supply should remove the grid-No.2 voltage when the dc grid-No.2 current reaches a value slightly higher than normal.

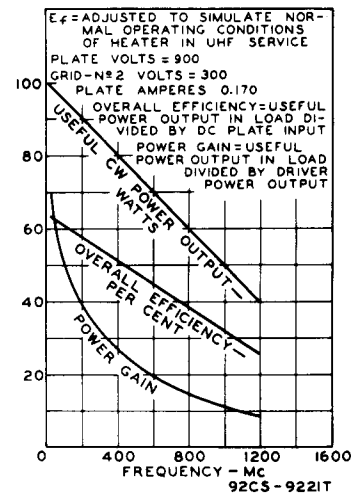
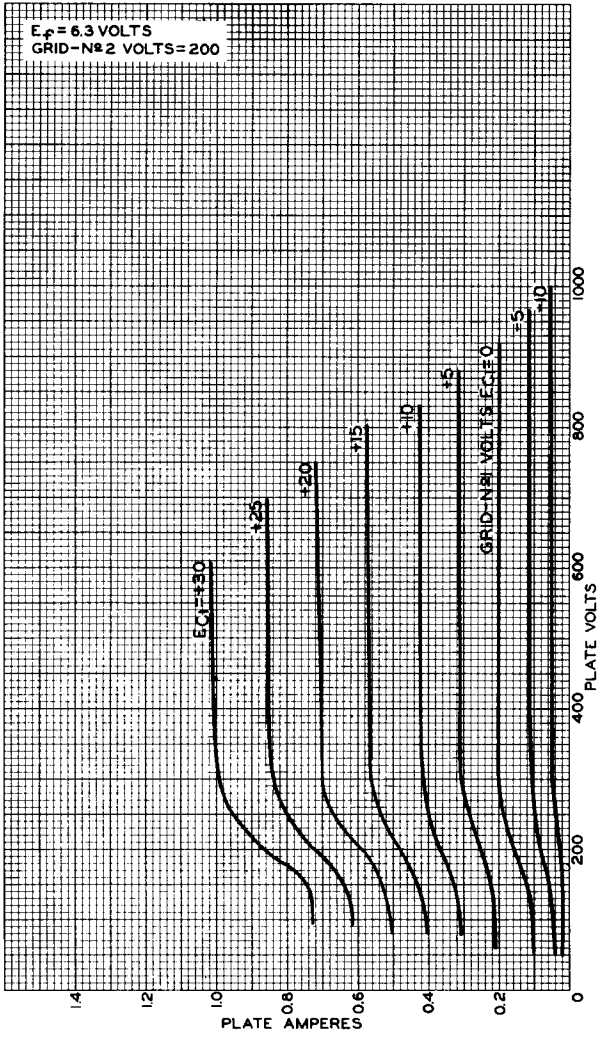

Fig. 5 - Typical Performance Characteristics of Type 6816 in Class C Telegraphy or Class C FM Telephony Amplifier Service.

The rated plate and grid-No.2 voltages of this tube are extremely dangerous to the user. Great care should be taken during the adjustment of circuits. The tube and its associated apparatus, especially all parts which may be at high potential above ground, should be housed in a protective enclosure. The protective housing should be designed with interlocks so that personnel can not possibly come in contact with any high-potential point in the electrical system. The interlock devices should function to break the primary circuit of the high-voltage supplies when any gate or door on the protective housing is opened, and should prevent the closing of the primary circuit until the door is again locked.

The driver stage for the 6816 in rf service should have considerably more output capability than the typical driving power shown in the tabulated data in order to permit considerable range of adjustment, and also to provide for losses in the grid-No.1 circuits and the coupling circuits. This recommendation is particularly important near the rated maximum frequency where circuit losses, radiation losses, and transit-time losses



92CM-9228

Fig. 6 - Typical Plate Characteristics of Type 6816

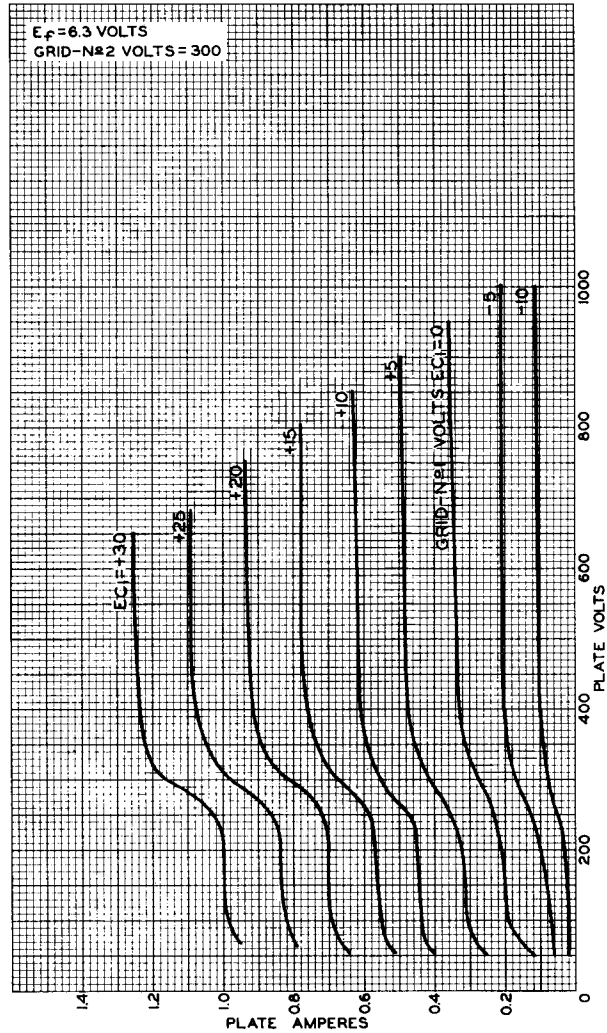

92CM-9222

Fig. 8 - Typical Plate Characteristics of Type 6816.

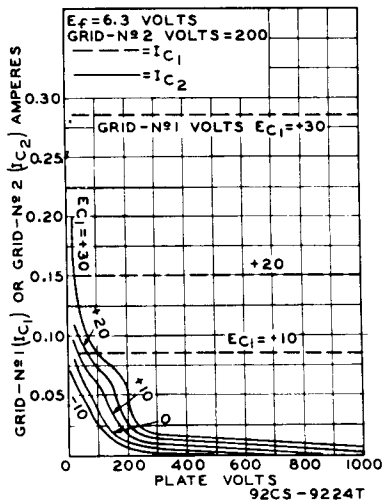

92CS-9224T

Fig. 7 - Typical Characteristics of Type 6816.

increase. Typical losses have been taken into account in the values of driver power output shown in the tabulated data.

In cathode-drive circuits, a further increase in driving power is required because the grid-No.1 driving voltage and the developed rf plate

voltage act in series to supply the load circuit. The increased driving power is not lost because it appears as output from the cathode-drive stage. If the driving voltage and grid-No.1 current are increased, the output will always increase. Such is not the case in a grid-drive circuit where a saturation effect takes place, i.e., above a certain value of driving voltage and current, the output increases very slowly and may even decrease. It is important to recognize this difference and not try to saturate a cathode-drive stage because the maximum grid-No.2 input may easily be exceeded.

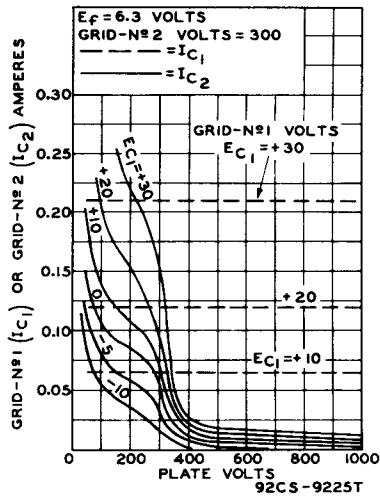

Fig. 9 - Typical Characteristics of Type 6816.

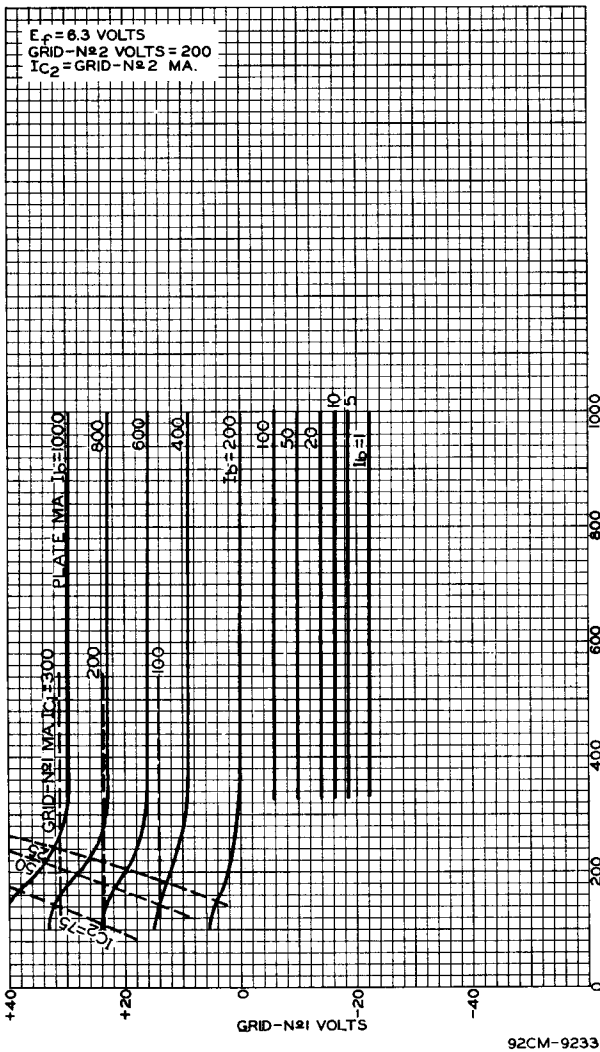

Fig. 10 - Typical Constant-Current Characteristics of Type 6816.

In tuning a cathode-drive rf amplifier, it must be remembered that variations in the load on the output stage will produce corresponding variations in the load on the driving stage. This effect will be noticed by the simultaneous increase in plate currents of both the output and driving stages.

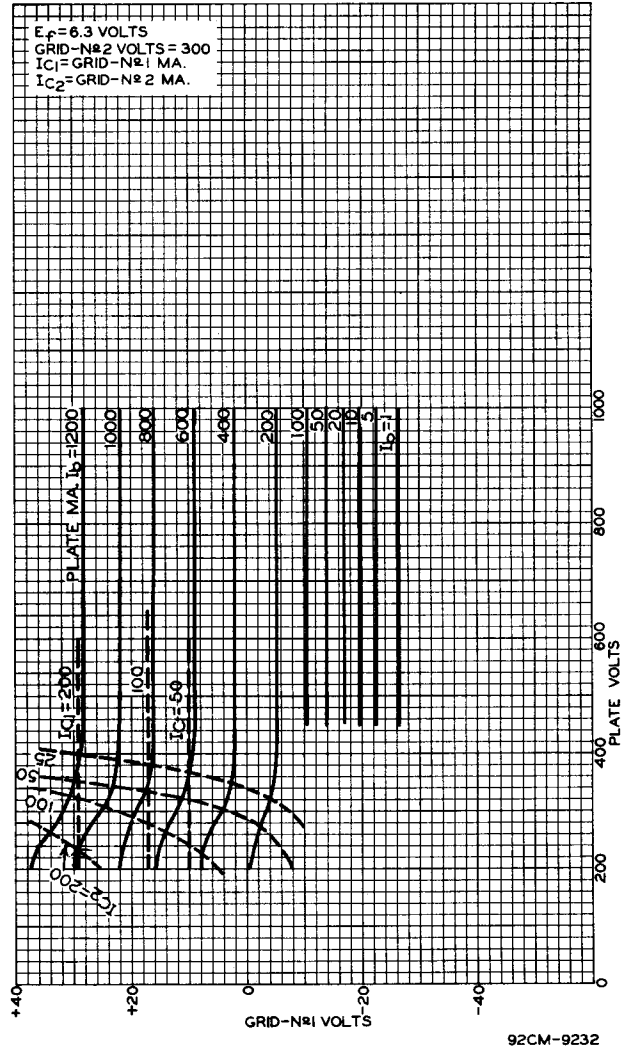

Fig. 11 - Typical Constant-Current Characteristics of Type 6816.

Typical performance curves for the 6816 are shown in Fig. 5.

In plate-modulated class C amplifier service, the 6816 can be modulated 100 per cent. The grid-No. 2 voltage must be modulated simultaneously with the plate voltage so that the ratio of grid-No. 2 voltage to plate voltage remains constant. Modulation of the grid-No. 2 voltage can be accomplished either by connecting grid No. 2 through a separate winding on the modulation transformer to the fixed grid-No. 2 voltage supply, or by



connecting grid No.2 through an audio-frequency choke of suitable impedance for low audio frequencies to the fixed grid-No.2 supply voltage. The supply end of the choke should be well bypassed to ground.

In class C rf telegraphy service, the 6816 may be supplied with bias by any convenient method except when the tube is used in the final amplifier or a preceding stage of a transmitter designed for break-in operation and oscillator keying. In this case, an amount of fixed bias

must be used to limit the plate current and, therefore, the plate dissipation to a safe value.

During standby periods in intermittent operation, it is recommended that the heater voltage be maintained at normal operating value when the period is less than 15 minutes; and that it be reduced to 80 per cent of normal when the period is between 15 minutes and 2 hours. For longer periods, the heater voltage should be turned off.

DIMENSIONAL OUTLINE

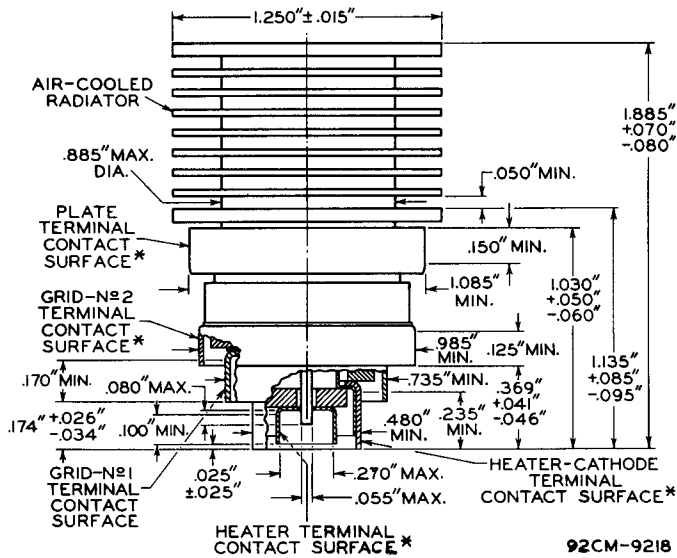

SKETCH G₁

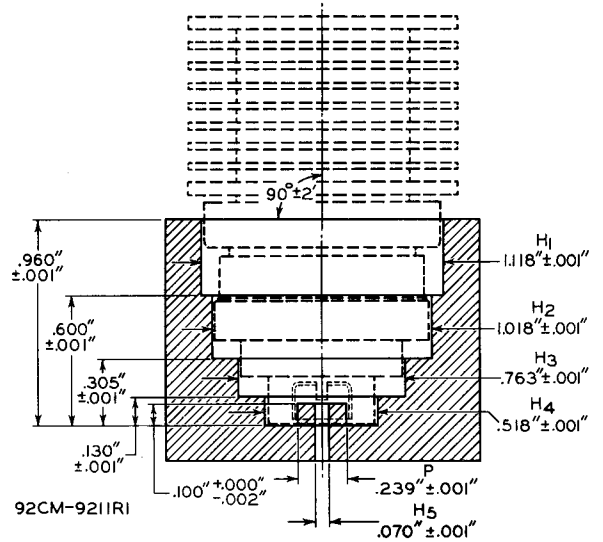

* WITH THE CYLINDRICAL SURFACES OF THE PLATE TERMINAL, GRID-NO.2 TERMINAL, GRID-NO.1 TERMINAL, HEATER-CATHODE TERMINAL, AND HEATER TERMINAL CLEAN, SMOOTH, AND FREE OF BURRS, THE TUBE WILL ENTER A GAUGE AS SHOWN IN SKETCH G₁. THE TUBE IS PROPERLY SEATED IN THE GAUGE WHEN A 0.010 THICKNESS GAUGE 1/8" WIDE WILL NOT ENTER BETWEEN THE HEATER-CATHODE TERMINAL AND THE BOTTOM SURFACE OF H₄. THE GAUGE IS PROVIDED WITH A SLOT TO PERMIT MAKING MEASUREMENT OF SEATING OF HEATER-CATHODE TERMINAL ON BOTTOM OF HOLE H₄.

THE AXES OF THE CYLINDRICAL HOLES H₁ THROUGH H₅ AND THE AXIS OF POST P ARE COINCIDENT WITHIN 0.001".

TERMINAL CONNECTIONS

- G₁ - Grid-No.1 Terminal Contact Surface (Adjacent to Cathode & Heater Terminal Contact Surface)
- G₂ - Grid-No.2 Terminal Contact Surface (Adjacent to Grid-No.1 Terminal Contact Surface)
- H - Heater Terminal Contact Surface (Within Cathode & Heater Terminal Contact Surface)

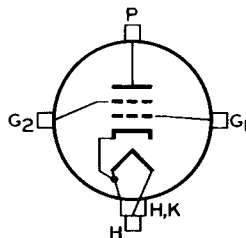

- H, K - Cathode & Heater Terminal Contact Surface (End Opposite Air-Cooled Radiator)
- P - Plate Terminal Contact Surface (Adjacent to Air-Cooled Radiator)

Devices and arrangements shown or described herein may use patents of RCA or others. Information contained herein is furnished without responsibility by RCA for its use and without prejudice to RCA's patent rights.