

DESCRIPTION:

THE 5956 IS A UNIPOTENTIAL CATHODE, THREE ELEMENT HYDROGEN FILLED THYRATRON DESIGNED FOR NETWORK DISCHARGE SERVICE. IN SUCH SERVICE IT IS SUITABLE FOR PRODUCING PULSE OUTPUTS OF MORE THAN 350 KW AT AN AVERAGE POWER LEVEL OF MORE THAN 400 WATTS. IT IS ESPECIALLY SUITABLE FOR COMPACT, AIRBORNE RADAR SYSTEMS.

THE SPECIAL FEATURES OF THE 5956 INCLUDE THE HIGH PEAK VOLTAGE AND CURRENT RATING, THE VERY COMPACT SIZE, AND A HYDROGEN RESERVOIR CONNECTED INTERNALLY ACROSS THE FILAMENT, CAPABLE OF MAINTAINING THE HYDROGEN PRESSURE THROUGHOUT THE USEFUL LIFE OF THE TUBE.

ELECTRICAL DATA, GENERAL:

	<u>NOM.</u>	<u>MIN.</u>	<u>MAX.</u>	
HEATER VOLTAGE	6.3	5.9	6.7	VOLTS A.C.
HEATER CURRENT (AT 6.3 VOLTS)		5.5	6.7	AMPERES
MINIMUM HEATING TIME				3 MINUTES

MECHANICAL DATA, GENERAL:

MOUNTING POSITION				ANY
BASE			A4-102	
ANODE CAP				PER OUTLINE
COOLING (NOTE 1)				
NET WEIGHT			4	OUNCES
DIMENSIONS				SEE OUTLINE

TYPICAL OPERATION AS PULSE MODULATOR, DC RESONANT CHARGING:

PEAK NETWORK VOLTAGE	8.0	KILOVOLTS
PULSE REPETITION RATE	4,500	PULSES/SECOND
PULSE LENGTH	0.25	MICROSECOND
PULSE FORMING NETWORK IMPEDANCE	50.2	OHMS
TRIGGER VOLTAGE	200	VOLTS
PEAK POWER OUTPUT (RESISTIVE LOAD 92% ZN)	311	KILOWATTS
PEAK ANODE CURRENT	83	AMPERES
AVERAGE ANODE CURRENT	0.094	AMPERES D.C.

RATINGS:

MAX. PEAK ANODE VOLTAGE, FORWARD	8.0	KILOVOLTS
MAX. PEAK ANODE VOLTAGE, INVERSE (NOTE 2)	8.0	KILOVOLTS
MIN. ANODE SUPPLY VOLTAGE	2.5	KILOVOLTS D.C.
MAX. PEAK ANODE CURRENT	83	AMPERES
MAX. AVERAGE ANODE CURRENT	100	MILLIAMPERES
MAX. RMS ANODE CURRENT (NOTE 3)	2.9	AMPERES A.C.
MAX. EPY x IB x PRR	2.5 x 10 ⁹	
MAX. ANODE CURRENT RATE OF RISE	1,200	AMPERE/ μ SECOND
PEAK TRIGGER VOLTAGE (NOTE 4)		
MAX. PEAK INVERSE TRIGGER VOLTAGE	200	VOLTS

	<u>INITIAL</u> <u>LIMIT</u>	<u>END OF LIMIT</u> <u>LIMIT</u>	
MAX. ANODE DELAY TIME (NOTE 5)	0.5	0.6	μ SECOND
MAX. ANODE DELAY TIME DRIFT	0.1	0.1	μ SECOND
MAX. TIME JITTER (NOTE 6)	0.01	0.02	μ SECOND
AMBIENT TEMPERATURE		-50° to 90°	CENT.
SHOCK RATING		24°	NAVY (FLYWEIGHT) SHOCK MACHINE
ALTITUDE		50,000	FEET AT 5.5 KV PEAK AND 57 AMPERES PEAK

NOTE 1:

COOLING PERMITTED. HOWEVER, THERE SHALL BE NO AIRBLAST DIRECTLY ON THE BULB.

NOTE 2:

THE PEAK INVERSE VOLTAGE SHOULD NOT EXCEED 2.5 KV DURING THE FIRST 25 MICROSECONDS AFTER CONDUCTION.

NOTE 3:

THE ROOT MEAN SQUARE ANODE CURRENT SHALL BE COMPUTED AS THE SQUARE ROOT OF THE PRODUCT OF THE PEAK CURRENT AND THE AVERAGE CURRENT.

NOTE 4:

THE VOLTAGE BETWEEN GRID AND CATHODE TERMINALS OF THE SOCKET WITH THE TUBE REMOVED SHOULD HAVE THE FOLLOWING CHARACTERISTICS.

- | | |
|---------------------|--------------------------------|
| A. VOLTAGE | 175-250 VOLTS |
| B. DURATION | 2 MICROSECONDS (AT 70% POINTS) |
| C. SOURCE IMPEDANCE | 1500 OHMS (MAX.) |
| D. RATE OF RISE | 200 VOLTS/MICROSECOND (MIN.) |

THE LIMITS OF ANODE TIME DELAY AND ANODE TIME JITTER ARE BASED ON THE MINIMUM TRIGGER. USING THE HIGHEST PERMISSIBLE TRIGGER VOLTAGE AND LOWEST TRIGGER SOURCE IMPEDANCE MATERIALLY REDUCES THESE VALUES BELOW THE LIMITS SPECIFIED.

NOTE 5:

THE TIME OF ANODE DELAY IS MEASURED BETWEEN THE 26 PERCENT POINT ON THE RISING PORTION OF THE UNLOADED GRID VOLTAGE PULSE AND THE POINT AT WHICH EVIDENCE OF ANODE CONDUCTION FIRST APPEARS ON THE LOADED GRID PULSE.

NOTE 6:

TIME JITTER IS MEASURED AT THE 50 PERCENT POINT ON THE ANODE CURRENT PULSE.

ADDITIONAL INFORMATION FOR SPECIFIC APPLICATIONS CAN BE OBTAINED FROM THE

ELECTRON TUBE APPLICATIONS SECTION
ITT COMPONENTS DIVISION
POST OFFICE BOX 412
CLIFTON, NEW JERSEY



TOP LEAD $.08 \pm .003$
TUNGSTEN WIRE

.188 MIN

- 1. HEATER
 - 2. CATHODE
 - 3. GRID
 - 4. HEATER CATHODE
- TOP LEAD - ANODE

.750
.0937
.375

1.390 o.d.

.625

CLAMPING AREA HERE.
CLAMP INSULATED
FROM GROUND .750

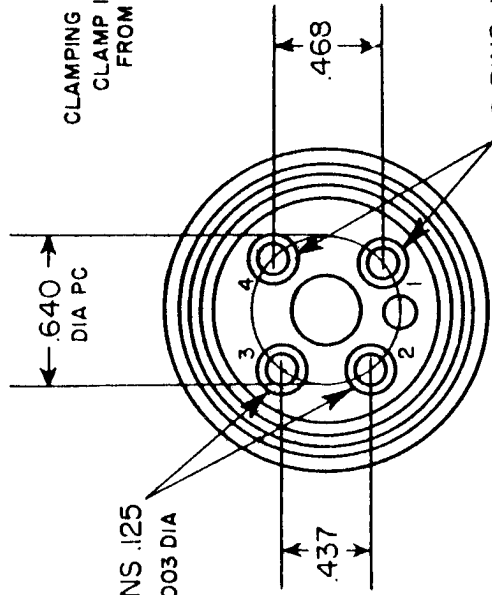

2 PINS $.125 \pm .003$ DIA

2 PINS $.156 \pm .003$ DIA

2.375 NOM

$1.50 \pm .06$

4.50 $\pm .250$

1.70 MAX

.969

.594

A 4 - 120 Base