

# FEDERAL POWER TRIODE Type F-6179 50 Kilowatts Plate Dissipation



## GENERAL DATA

### DESCRIPTION:

The F-6179 is a three-electrode tube designed for use as a modulator. The anode is water-cooled and capable of dissipating 50 kilowatts. The cathode is a pure tungsten filament. Maximum ratings apply for audio-frequency use only.

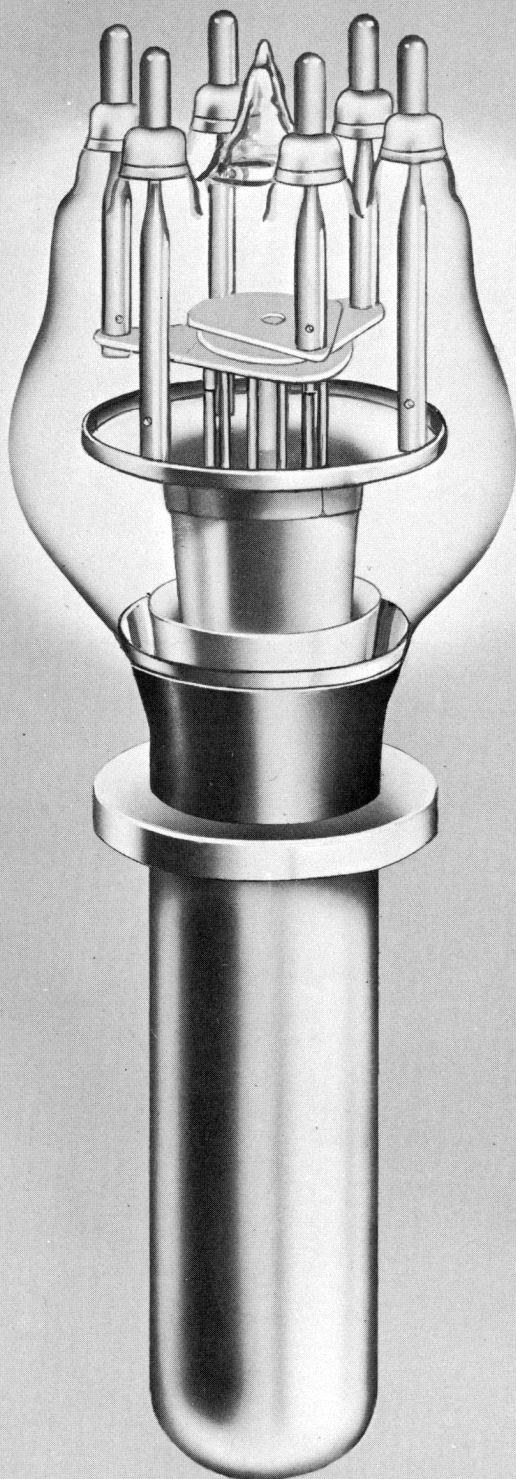

### Electrical:

▶ Filament Voltage	27.2 Volts
▶ Filament Current	196.5 Amperes
▶ Filament Starting Current	300 Amperes
▶ Filament Cold Resistance	.015 Ohms
▶ Amplification Factor, at $E_c = -1,600 \text{ V}$ $I_b = 3.0 \text{ A}$	4.75
▶ Interelectrode Capacitances	
Grid-Plate	61 $\mu\mu\text{f}$
Grid-Filament	63 $\mu\mu\text{f}$
Plate-Filament	0.6 $\mu\mu\text{f}$

### Mechanical:

▶ Mounting Position—	
Vertical, Anode Down	
▶ Type of Cooling—Water	
Water Flow on Anode	20 GPM
Maximum Outgoing	
Water Temperature	70° C
Maximum Glass Temperature	150° C
▶ Net Weight, approximate	10 Lbs.

# FEDERAL POWER TRIODE Type F-6179 50 Kilowatts Plate Dissipation



Federal always has made *first-quality* tubes, and the record goes back for more than 40 years.

## Maximum Ratings and Typical Operating Conditions

### AUDIO-FREQUENCY POWER AMPLIFIER AND MODULATOR—CLASS AB<sub>1</sub>

#### Maximum Ratings, Absolute Values

DC Plate Voltage	15,000 Volts
Maximum Signal DC Plate Current†	10 Amperes
Maximum Signal Plate Input†	120 Kilowatts
Plate Dissipation†	50 Kilowatts

#### Typical Operation

(Unless otherwise specified, values are for two tubes)

DC Plate Voltage	12,000 Volts
DC Grid Voltage	-2,600 Volts

Peak A-F Grid to Grid Voltage	5,160 Volts
Zero Signal DC Plate Current	1.8 Amperes
Maximum Signal DC Plate Current	5.3 Amperes
Effective Load Resistance Plate to Plate	5,000 Ohms
Maximum Signal Driving Power	0 Watts
Maximum Signal Power Output	40 Kilowatts

For Characteristic Curves refer to Federal Type F-125-A.

†Averaged over any audio-frequency cycle of sine-wave form.

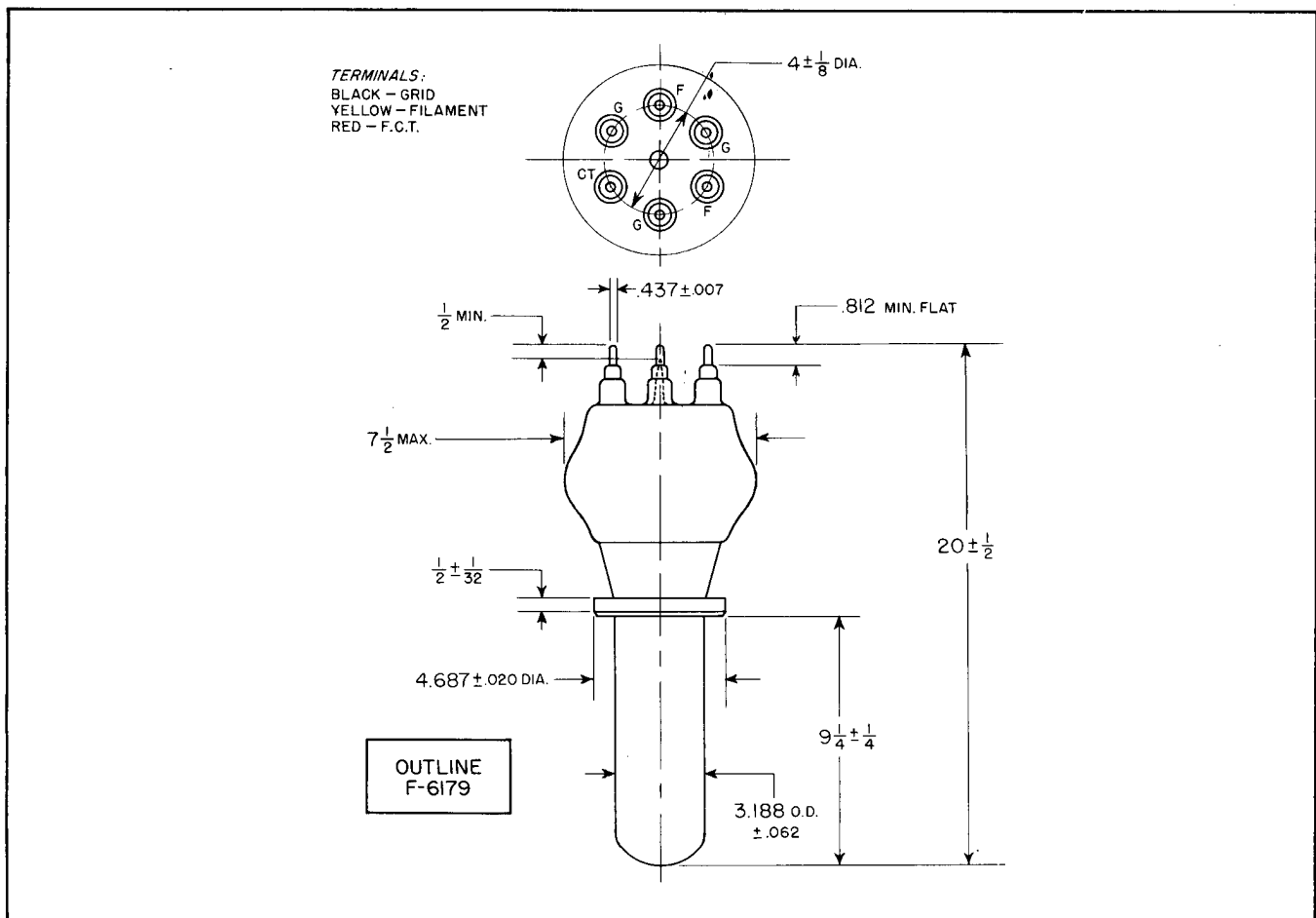

# Federal Telephone and Radio Company

100 Kingsland Road VACUUM TUBE DEPARTMENT Clifton, New Jersey