

National Video Corporation

4300 W. 47TH STREET CHICAGO 32, ILLINOIS
CLIFFSIDE 4-5600

The 16BRP4 is a 16"-114° banded cathode ray tube with a 4 1/8" neck length. This tube has electrostatic focus, magnetic deflection, a straight gun which requires no ion trap, and a 600 milliamperere 6.3 volt filament.

ELECTRICAL DATA

Focusing Method	Electrostatic
Deflection Angles, Approximate	
Horizontal	103 Degrees
Vertical	87 Degrees
Diagonal	114 Degrees
Direct Interelectrode Capacitances	
Cathode to all other electrodes, approximate	5 uuf
Grid #1 to all other electrodes, approximate	6 uuf
External conductive coating to anode	1500 Max. uuf
	1000 Min. uuf
Heater Current at 6.3 Volts	600 +30 ma
Heater Warm-up Time	11 Seconds

OPTICAL DATA

Phosphor number JEDEC designation	P4 Aluminized
Light Transmittance	53 Percent

MECHANICAL DATA

Overall Length	10 9/32 <u>+5/16</u> Inches
Greatest Diameter of Tube	
Greatest Dimensions of Tube	
Diagonal	
Width	13 15/16 Max. Inches
Height	11 11/32 Max. Inches
Minimum Useful Screen Diameter (Projected)	
Minimum Useful Screen Dimensions (Projected)	
Diagonal	14 7/8 Inches
Horizontal Axis	12 15/16 Inches
Vertical Axis	10 1/4 Inches
Area	125 Sq. Inches
Neck Length	4 1/8 <u>+1/8</u> Inches
Bulb EIA designation or equivalent (including shield designation)	J125-B1
Bulb Contact	JEDEC Designation J1-21
Base	JEDEC Designation 8HR
Basing	JEDEC Designation B7-208
Bulb Contact Alignment	
J1-21 contact aligns with pin position #2	<u>+30</u> degrees.

RATINGS (Design Maximum System)

Unless otherwise specified, voltage values are positive and measured with respect to Cathode

Maximum Anode Voltage	18,000 Volts
Minimum Anode Voltage	10,000 Volts
Maximum Grid #4 (Focusing Electrode) Voltage	+1100 -500
Maximum Grid #2 Voltage	550 Volts
Minimum Grid #2 Voltage	200 Volts
Grid #1 Voltage	
Maximum Negative Value	155 Volts DC
Maximum Negative Peak Value	220 Volts
Maximum Positive Value	0 Volts DC
Maximum Positive Peak Value	2 Volts
Maximum Heater Voltage	6.9 Volts
Minimum Heater Voltage	5.8 Volts
Maximum Heater-Cathode Voltage	
Heater negative with respect to cathode	
During warm-up period not to exceed 15 seconds	450 Volts
After equipment warm-up period	200 Volts
Heater positive with respect to cathode	200 Volts

TYPICAL OPERATING CONDITIONSCATHODE DRIVE SERVICE

Unless otherwise specified, all voltage values are positive with respect to Cathode

Anode Voltage	15,000 Volts DC
Grid #4 Voltage (Focusing Electrode) (Notes 2 & 3)	250 Volts DC
Grid #2 Voltage	400 Volts DC
Grid #1 Voltage (Note 1)	-46 to -94 Volts DC

MAXIMUM CIRCUIT VALUES

Maximum Grid #1 Circuit Resistance	1.5 Megohms
------------------------------------	-------------

GRAPHS AND DRAWINGS

Tube outline with essential dimensions and tolerances.

Pin Connections:

Pin 1	Heater	Pin 6	Grid No. 1
Pin 2	Grid No. 1	Pin 7	Cathode
Pin 3	Grid No. 2	Pin 8	Heater
Pin 4	Grid No. 4		

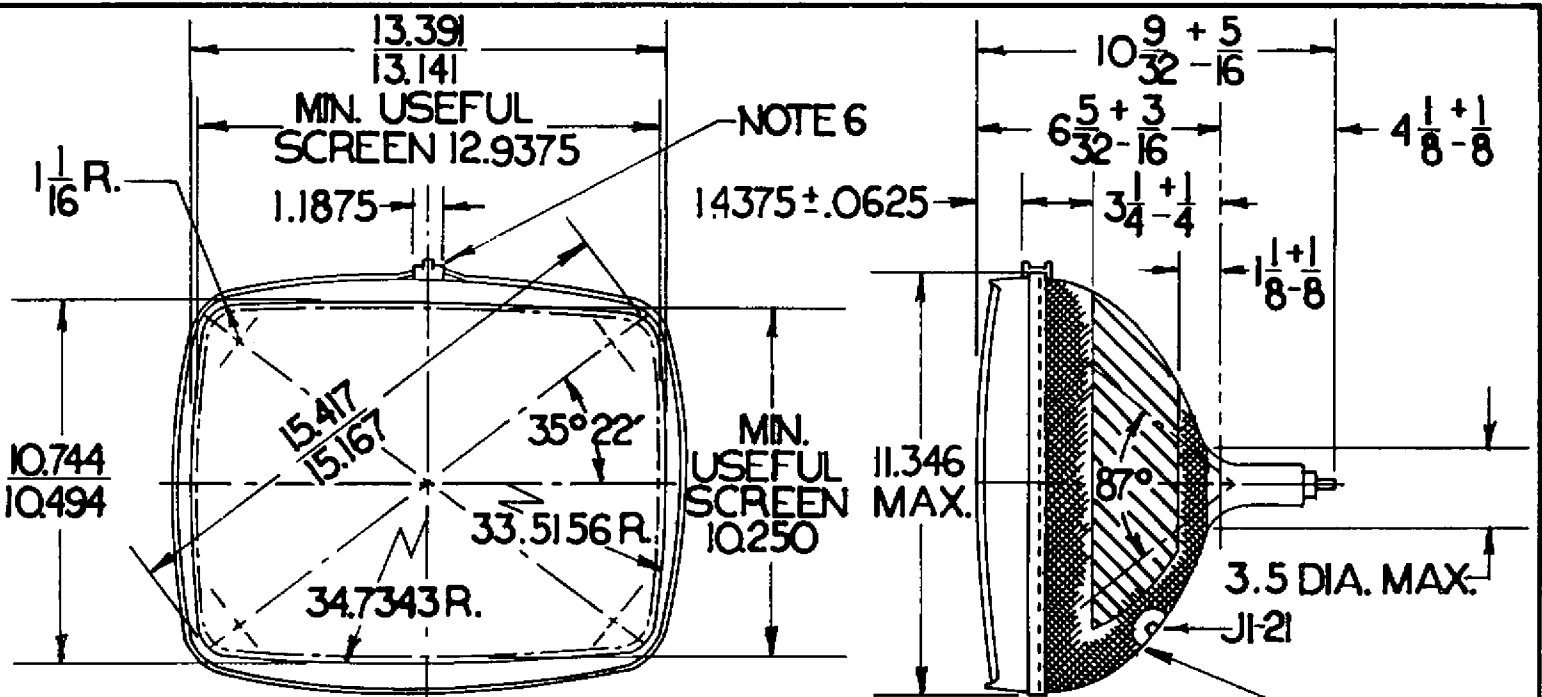

NOTE 6

1.4375 ± .0625

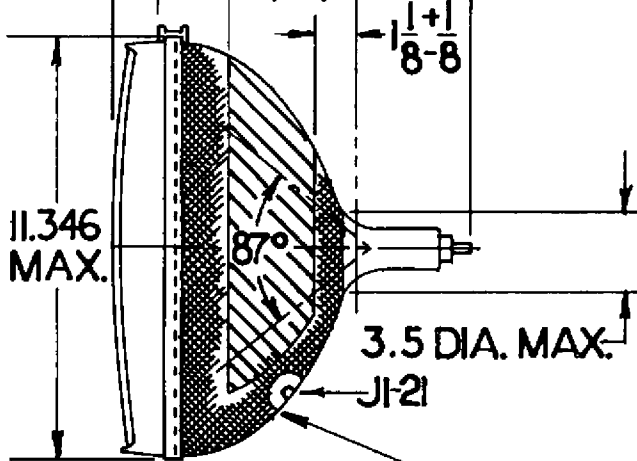

2" MAX. DIA. HOLE CUT IN CLOTH FOR ANODE TERMINAL

TENSION BAND

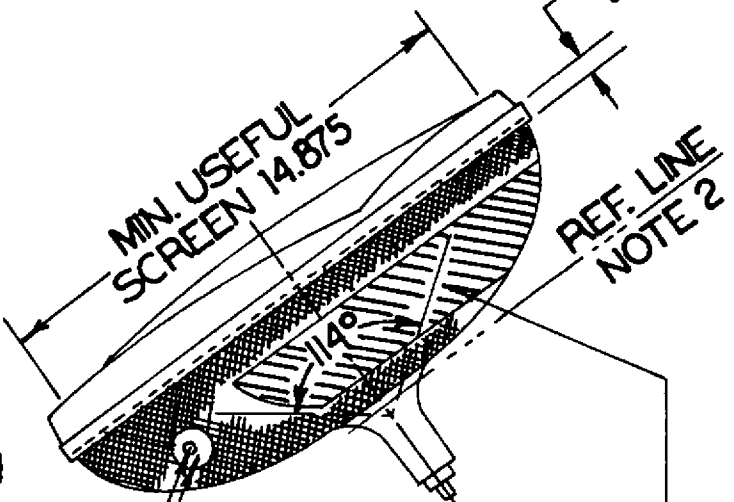
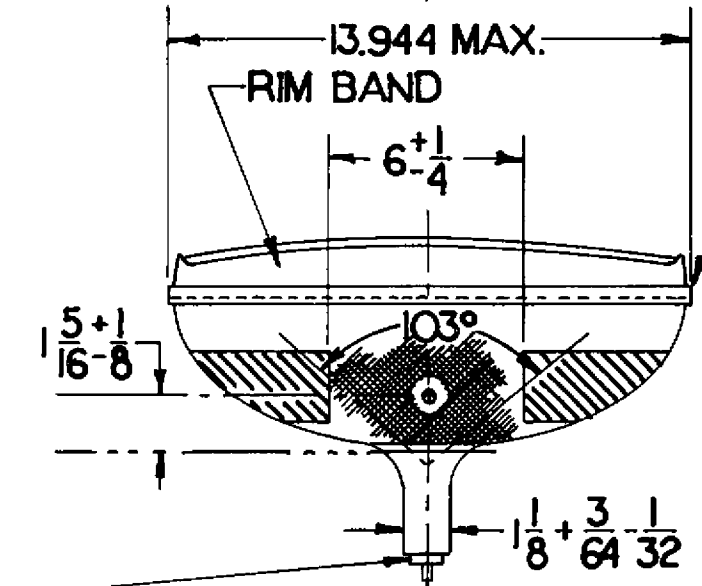

SMALL BUTTON NINE EIGHT STAR 7 PIN BASE ARRANGEMENT 1 JEDEC # B7-208 (NOTE 3)

SOCKET CONNECTIONS

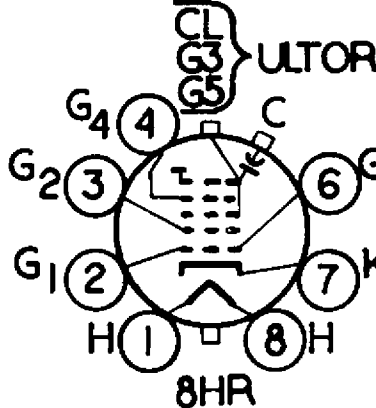

- PIN 1: HEATER
- PIN 2: GRID NO. 1
- PIN 3: GRID NO. 2
- PIN 4: GRID NO. 4
- PIN 6: GRID NO. 1
- PIN 7: CATHODE
- PIN 8: HEATER

CAP: ULTOR (GRID NO. 3 GRID NO. 5 COLLECTOR)

C: EXTERNAL CONDUCTIVE COATING

DRAWN BY A.L. PRIBYL	SCALE	EFFECTIVE 8-15-63	DISTRIBUTION	DRAWING NO. 16BRP4
-------------------------	-------	----------------------	--------------	-----------------------

NOTES

1. Visual extinction of focused raster.
2. With the combined grid #1 bias voltage and video-signal voltage adjusted to give an anode current of 100 microamperes on a 12 15/16" X 10 1/4" pattern from RCA 2F21 Monoscope or equivalent.
3. Individual tubes will have satisfactory focus at some value between 0 and 400 volts.

NOTES FOR DIMENSIONAL OUTLINE

1. The plane through the tube axis and Pin No. 2 may vary from the plane through the tube axis and ultor terminal by angular tolerance (measured about the tube axis) of $\pm 30^{\circ}$. Ultor terminal is on same side as Pin No. 2.
2. With tube neck inserted through flared end of reference-line gauge JEDEC No. G-126 and with tube seated in gauge, the reference-line is determined by the intersection of the plane CC' of the gauge with the glass funnel.
3. Socket for this base should not be rigidly mounted; it should have flexible leads and be allowed to move freely. The design of the socket should be such that the circuit wiring cannot impress lateral strains through the socket contacts on the base pins. Bottom circumference of base wafer will fall within a circle concentric with bulb axis and having a diameter of 1 3/4".
4. External conductive coating must be grounded.
5. To clean this area, wipe only with soft dry lint-less cloth.
6. Tension band clip may extend an additional .075" from dimensions specified.